

**PUBLIC VERSION**

**UNITED STATES INTERNATIONAL TRADE COMMISSION**

**Washington, D.C.**

**In the Matter of**

**CERTAIN RAISED GARDEN BEDS AND  
COMPONENTS THEREOF**

**Inv. No. 337-TA-1334**

**INITIAL DETERMINATION ON VIOLATION OF SECTION 337 AND  
RECOMMENDED DETERMINATION ON REMEDY AND BOND**

Administrative Law Judge Doris Johnson Hines

(September 8, 2023)

**Appearances:**

*For Complainant Vego Garden, Inc.:* Bryan G. Harrison and Ziwen Zhu of LOCKE LORDE LLP, Atlanta, Georgia and Mark Hannemann of LOCKE LORDE LLP, New York, New York.

*For Respondents Huizhou Green Giant Technology Co., Ltd. and Utopban Limited:* Yu-Hao Yao and Tianyu Ju of GLACIER LAW LLP, Pasadena, California and Wei Wang of GLACIER LAW LLP, New York, New York.

*For the Office of Unfair Import Investigations:* Margaret D. Macdonald, David O. Lloyd, and Megan Wantland, U.S. International Trade Commission, Washington, DC.

**PUBLIC VERSION**

**Table of Contents**

I.	Introduction.....	1
A.	Procedural History .....	1
B.	The Private Parties .....	3
1.	Complainant.....	3
2.	Respondents .....	4
C.	Alleged Trade Secrets .....	5
D.	Alleged Unfair Competition .....	6
E.	Products at Issue .....	6
1.	Accused Products.....	6
2.	Domestic Industry Products.....	7
II.	Jurisdiction.....	9
A.	Statutory Jurisdiction .....	9
B.	Personal Jurisdiction .....	12
C.	<i>In Rem</i> Jurisdiction .....	12
III.	Standing .....	13
A.	Standing to Assert Trade Secret Misappropriation.....	13
B.	Standing to Assert False Advertising.....	13
IV.	Importation.....	14
V.	Whether There Are Protectable Trade Secrets.....	15
A.	Vego Garden’s Identification of the Asserted Trade Secrets.....	18
B.	Identification of the Involved Entities .....	20
C.	The Asserted 8-Inch Product Development Trade Secret.....	20
1.	Extent the Trade Secret Was Known Outside Vego Garden .....	21
2.	Extent All Trade Secrets Were Known Inside Vego Garden .....	26
3.	Steps Taken By Vego Garden to Protect the Trade Secret .....	29
4.	Value of the Trade Secret to Vego Garden and Competitors .....	33
5.	Amount of Effort or Money Expended in Development .....	35
6.	Extent the Trade Secret Is Readily Ascertainable.....	36
7.	Conclusion .....	37
D.	The Asserted Protective Film Trade Secret .....	38
1.	Extent the Trade Secret Was Known Outside Vego Garden .....	38
2.	Extent the Trade Secret Was Known Inside Vego Garden.....	40

**PUBLIC VERSION**

3. Steps Taken by Vego Garden to Protect the Trade Secret..... 41

4. Value of the Trade Secret to Vego Garden and Competitors ..... 42

5. Amount of Effort or Money Expended in Development ..... 43

6. Extent the Trade Secret Is Readily Ascertainable..... 44

7. Conclusion ..... 45

E. The Asserted Bending Machine Trade Secret ..... 45

1. Extent the Trade Secret Was Known Outside Vego Garden ..... 46

2. Extent the Trade Secret Was Known Inside Vego Garden..... 50

3. Steps Taken by Vego Garden to Protect the Trade Secret..... 50

4. Value of the Trade Secret to Vego Garden and Competitors ..... 51

5. Amount of Effort or Money Expended in Development ..... 52

6. Extent the Trade Secret Is Readily Ascertainable..... 53

7. Conclusion ..... 54

VI. Misappropriation of the Asserted Trade Secrets..... 55

A. Ownership..... 55

B. Wrongful Disclosure or Acquisition..... 56

1. Materials from Shun Chuen Were Properly Considered ..... 57

2. The Confidentiality Obligations of Mr. Lu and Mr. Yu ..... 60

3. Wrongful Disclosure or Acquisition by Mr. Lu..... 68

4. Wrongful Disclosure or Acquisition by Mr. Yu ..... 70

C. Use of the Asserted Trade Secrets ..... 78

1. The 8-Inch Product Development Research Trade Secret..... 80

2. The Protective Film Trade Secret ..... 80

3. The Bending Machine Trade Secret ..... 81

VII. Respondents’ Affirmative Defense of Independent Development ..... 83

VIII. Unfair Competition ..... 85

A. Vego Garden’s False Advertising Claim Is Not Moot..... 86

B. Vego Garden Owns the Photographs Utopban Used on Its Website and Instagram  
..... 87

C. Utopban Engaged in False Advertising ..... 88

1. Utopban Made False Statements..... 89

2. Utopban’s False Statements Were Deceptive..... 94

3. Utopban’s False Statements Were Material..... 95

**PUBLIC VERSION**

4.	Utopban’s False Advertisements Entered into Interstate Commerce .....	96
5.	Vego Garden Was Injured by Utopban’s False Statements.....	103
IX.	Domestic Industry .....	103
A.	Existence of a Domestic Industry .....	104
1.	Investments in and Expenditures on Qualifying Activities .....	105
2.	Significance of Investments in and Expenditures on Qualifying Activities .....	118
B.	Injury to the Domestic Industry .....	123
1.	Vego Garden Has Demonstrated Substantial Injury to Its Domestic Industry .....	123
2.	There Is a Causal Nexus Between Respondents’ Unfair Acts and the Substantial Injury to Vego Garden .....	131
X.	Conclusions of Law .....	136
XI.	Recommended Determination on Remedy and Bond.....	137
A.	Limited Exclusion Orders .....	137
1.	Limited Exclusion Order Addressing Trade Secret Misappropriation ...	138
2.	Limited Exclusion Order Addressing False Advertising .....	142
B.	Cease and Desist Orders .....	143
C.	Bond During Presidential Review .....	145
XII.	Initial Determination on Violation.....	148
XIII.	Order .....	148

## PUBLIC VERSION

This is the final Initial Determination in the matter of *Certain Raised Garden Beds and Components Thereof*, Investigation No. 337-TA-1334 pursuant to the Notice of Investigation, 87 Fed. Reg. 63527 (Oct. 19, 2022), 19 C.F.R. §§ 210.10(b) and 210.42(a)(1)(i).

### I. INTRODUCTION

#### A. Procedural History

Vego Garden, Inc. filed a Complaint on September 13, 2022, (EDIS Doc. ID 780063), and filed a letter supplementing its Complaint, (EDIS Doc. ID 780781), and an Amended Complaint on September 21, 2022, (EDIS Doc. ID 780825). The Amended Complaint alleges violations of section 337 based on the importation into the United States, and in the sale of, certain raised metal garden beds and components thereof due to misappropriation of trade secrets and unfair competition, the threat or effect of which is to destroy or substantially injure a domestic industry.

The Commission instituted Investigation No. 337-TA-1334 on October 13, 2022, to determine “whether there is a violation of subsection (a)(1)(A) of section 337 in the importation into the United States, or in the sale of, certain products identified in paragraph (2) by reason of misappropriation of trade secrets and unfair competition, the threat or effect of which is to destroy or substantially injure a domestic industry in the United States.” 87 Fed. Reg. 63527.

The plain language description of the accused products in the Notice of Investigation defines the scope of the investigation. 19 C.F.R. § 210.10(b)(1). The accused products are described as “raised metal garden beds.” 87 Fed. Reg. 63527.

The Notice of Investigation named the following respondents:

1. Huizhou Green Giant Technology Co., Ltd. (Green Giant);
2. Utopban International Trading Co., Ltd., d/b/a Vegega;
3. Utopban Limited (Utopban);

## PUBLIC VERSION

4. Forever Garden<sup>1</sup>; and
5. VegHerb, LLC, d/b/a Frame It All.

*Id.* Vego Garden's Amended Complaint named Kinghood International Logistics Inc. and Quanzhou Jieliya Trading Co., Ltd. as proposed respondents but the Commission determined not to institute an investigation as to either of those entities. Commission Letter (Oct. 13, 2022) (EDIS Doc. ID 782236). The Office of Unfair Import Investigations is also a party to this investigation. 87 Fed. Reg. 63527.

The presiding Chief Administrative Law Judge set the target date for this investigation at fourteen months. Order No. 4 (Nov. 2, 2022) (EDIS Doc. ID 783633). I extended the target date three weeks, to January 8, 2024, making this initial determination due on September 8, 2023. Order No. 31 (Aug. 16, 2023) (EDIS Doc. ID 802501).

The investigation was terminated as to respondent Utopban International Trading Co., Ltd. based on withdrawal of the Amended Complaint. Order No. 9 (Jan. 30, 2023) (EDIS Doc. ID 788929), *unreviewed by*, Comm'n Notice (Feb. 27, 2023) (EDIS Doc. ID 791164). The investigation was terminated as to respondents Forever Garden and VegHerb based on settlement agreements. Order No. 11 (Feb. 23, 2023) (VegHerb) (EDIS Doc. ID 790964) and Order No. 12 (Feb. 23, 2023) (Forever Garden) (EDIS Doc. ID 790965), both *unreviewed by*, Comm'n Notice (Mar. 23, 2023) (EDIS Doc. ID 793043). Respondents Green Giant and Utopban remain in the investigation.

---

<sup>1</sup> The Chief Administrative Law Judge issued an Initial Determination granting Vego Garden's motion to amend the Complaint and Notice of Investigation to correct the name of originally-named respondent The Hydro Source, Inc., d/b/a Forever Garden Beds, to Forever Garden. Order No. 8 (EDIS Doc. ID 786303).

## PUBLIC VERSION

Green Giant filed a counterclaim under 19 U.S.C. § 1337(c) and 19 C.F.R. § 210.14(e), seeking, among other things, a declaratory judgment that Green Giant has not misappropriated any of Vego Garden's alleged trade secrets and confidential information, in violation of the Defend Trade Secrets Act, 18 U.S.C. § 1836. Counterclaim, ¶¶ 46–54 (EDIS Doc. ID 786929). As required by 19 C.F.R. § 210.14(e), Green Giant removed its counterclaim to district court and that action is currently pending in the United States District Court for the Southern District of Texas, Houston Division, Case No. 4:23-cv-311.

On February 27, 2023, the presiding Chief Administrative Law Judge issued a Notice reassigning this investigation to me. Notice to the Parties (Feb. 27, 2023) (EDIS Doc. ID 791315).

In accordance with Ground Rule 11.2, (Order No. 14) (EDIS Doc. ID 792150), the parties filed pre-hearing briefs. Complainant Pre-Hearing Br. (EDIS Doc. ID 795228); Respondents Pre-Hearing Br. (EDIS Doc. ID 795236); and Staff Pre-Hearing Br. (EDIS Doc. ID 796340). The evidentiary hearing was held May 22–25, 2023. Thereafter, the parties filed post-hearing briefs. Complainant Post-Hearing Br. (EDIS Doc. ID 797960); Respondents Post-Hearing Br. (EDIS Doc. ID 797959); Staff Post-Hearing Br. (EDIS Doc. ID 798780); Complainant Post-Hearing Resp. Br. (EDIS Doc. ID 799091); Respondents Post-Hearing Resp. Br. (EDIS Doc. ID 799026); and Staff Post-Hearing Resp. Br. (EDIS Doc. ID 799331).

### **B. The Private Parties**

#### **1. Complainant**

Vego Garden is a corporation organized and existing under the laws of the State of Delaware, with its principal place of business at 1521 Greens Rd. #100, Houston, Texas, 77032. Amended Complaint, ¶ 2.1. Vego Garden was formally founded at the end of 2020 for the purpose of providing raised metal garden products to the U.S. market. *Id.*; Tr. (Xiong) at 25:18–26:14.

## PUBLIC VERSION

### 2. Respondents

Of the five respondents named in the Notice of Investigation, one was terminated by withdrawal of the Complaint, two were terminated based on settlement agreements and two, Green Giant and Utopban, proceeded to the evidentiary hearing.

#### a) Green Giant

Green Giant was founded in July 2021 and manufactures the accused raised metal garden bed products and accessories. Tr. (Lu) at 334:19–335:2; and Tr. (Li) at 329:12–15. Green Giant is based in China and has its principal place of business at Xiao Ao Tou, Hong Tian Management Area, Xin Yu Zhen, Hui Yang District, Hui Zhou, Guangdong, China. Amended Complaint, ¶ 3.1; and Green Giant Response to Amended Complaint, ¶ 3.1 (EDIS Doc. ID 785631). Though Green Giant does not sell directly into the United States, as of its Response to the Amended Complaint, the United States market represented around 85% of its business operations. Respondents Post-Hearing Br. at 4; and Ex. A to Green Giant Response to Amended Complaint, ¶ d (EDIS Doc. ID 785906).

#### b) Utopban

Utopban Limited is a limited company organized and existing under the laws of Hong Kong, with its principal place of business at Unit 2 22/F Richmond Comm. Bldg, 109 Argyle Street, Mongkok KL, Hong Kong 999077. Amended Complaint, ¶ 3.3; and Utopban Response to Amended Complaint, ¶ 3.3 (EDIS Doc. ID 785627). Utopban does business under the name “Vegega.” Utopban Response to Amended Complaint, ¶ 3.2; *see also* Amended Complaint, ¶ 3.2 (identifying Vegega as having an office location at 2646 River Ave., Suite #A, Rosemead, CA 91770). Utopban’s supplier of raised metal garden bed products is Green Giant. SX-0042.0005; Ex. A to Utopban Response to Amended Complaint, ¶ e (EDIS Doc. ID 785823); and Tr. (Li) at



## PUBLIC VERSION

329:8–15. As of its Response to the Amended Complaint, the U.S. market represented around 71% of Utopban’s business operations. Ex. A to Utopban Response to Amended Complaint, ¶ d. More than 90% of Utopban’s raised metal garden bed products are sold in the United States. Tr. (Li) at 325:21–25. In the year before filing its Response to the Amended Complaint, Utopban stated that it imported 5,350 raised metal garden bed products into the United States. Ex. A to Utopban Response to Amended Complaint, ¶ a.

### C. Alleged Trade Secrets

Under the Procedural Schedule, Vego Garden was required to serve by December 5, 2022, a Preliminary Disclosure that, among other things, included an identification of “each alleged trade secret allegedly misappropriated . . . by each respondent.” Order No. 6 (EDIS Doc. ID 784843); *see also* Complainant’s Preliminary Disclosure (EDIS Doc. ID 793340-1969262).

Vego Garden has identified what it contends are three trade secrets:

- 1. Product Development Research Trade Secret**, *i.e.*, Vego’s product development research relating to 8-inch raised garden bed configurations, an entirely new product line for consumers who could not afford Vego’s traditional 17-inch product.
- 2. Product Materials Research Trade Secret**, *i.e.*, Vego’s research and experimentation relating to the protective film used to protect the finish during manufacture and shipping of its raised metal garden bed products.
- 3. Product Manufacturing Trade Secret**, *i.e.*, Vego’s design improvements to the machinery used to generate curves or bends in the wave-form pattern in panels used in Vego’s raised garden bed configurations as a result of Vego’s research and development efforts.

Complainant Post-Hearing Br. at 16–17; *see also id.* at 10–15; Amended Complaint, ¶¶ 5.1–5.5; Confidential Ex. 1 to Complaint (EDIS Doc. ID 779976), ¶¶ 12–18; and Complainant Pre-Hearing Br. at 7–9.

## PUBLIC VERSION

### **D. Alleged Unfair Competition**

Vego Garden bases its unfair competition allegations on the Lanham Act, specifically on 15 U.S.C. § 1125(a), asserting that Utopban used photographs owned by Vego Garden to advertise Respondents' raised metal garden bed products. Complainant Pre-Hearing Br. at 21–22; *see also* Amended Complaint, ¶¶ 6.1–6.6. Vego Garden claims that Utopban's use of its photographs is false advertising under 15 U.S.C. § 1125(a)(1)(A). Complainant Pre-Hearing Br. at 21–26; *see also* Amended Complaint, ¶¶ 6.1–6.6.

Vego Garden previously asserted that Utopban committed the unfair act of reverse palming off, which it argued constituted false designation of origin under 15 U.S.C. § 1125(a)(1)(A). Complainant Pre-Hearing Br. at 21–26; *see also* Amended Complaint, ¶¶ 6.1–6.6. In its post-hearing response brief, Vego Garden withdrew its reverse palming off claim. Complainant Post-Hearing Resp. Br. at 3, n.1 (“Vego . . . agrees . . . to withdraw Vego's reverse palming off claim”); *see also* Staff Post-Hearing Resp. Br. at 13. Having withdrawn its reverse palming off claim, I do not address it here.

### **E. Products at Issue**

#### **1. Accused Products**

The accused products are raised metal garden bed products and components manufactured by Green Giant in China, sold for importation by Green Giant, imported by Utopban (also called Vegega) and sold through on-line distributors and retailers. Tr. (Li) at 329:3–15 (Utopban sells its raised metal garden bed products in the United States under the brand name Vegega, all of which are manufactured by Green Giant); Tr. (Lu) at 334:25–335:2 (Green Giant manufactures raised

## PUBLIC VERSION

metal garden bed products and accessories); CX-0500 (Lu Dep.) at 28:7–24<sup>2</sup> (Utopban investigated raised metal garden bed products customers in the U.S. would want); and CX-0019 (showing available Green Giant products with materials that “satisfy North American USDA regulations”). An example of an accused raised metal garden bed product is shown below:



CX-0019 at VEGO-ITC000153.

### **2. Domestic Industry Products**

Vego Garden’s domestic industry products are raised metal garden beds, an example of which is shown below.

---

<sup>2</sup> Although not highlighted in Exhibit CX-0500, this testimony was designated pursuant to Order No. 24 (EDIS Doc. ID 796880).

PUBLIC VERSION



CX-0065; *see also* CX-0064; CX-0066; CX-0068; CX-0069; CX-0072; and CX-0074.

Vego Garden’s raised metal garden bed products are manufactured in China. Tr. (Xiong) at 97:14–22. They come in various heights and colors. JX-0010 (spreadsheet of raised garden bed products and components available from Vego Garden); JX-0013C (spreadsheet of Vego Garden sales from January 1 to December 31, 2022)<sup>3</sup>; and CX-0038C (spreadsheet of Vego Garden sales from January 1 to February 28, 2023). Vego Garden’s domestic industry products directly compete in the U.S. market with Respondents’ accused products. Tr. (Xiong) at 42:10–14 (identifying Vegega as a competitor to Vego Garden); Tr. (Xiong) at 43:6–14 (identifying Green Giant

---

<sup>3</sup> JX-0011C was initially identified and relied on by the parties. It is identical to JX-0013C. In the exhibit list filed by the parties on September 5 (EDIS Doc. ID 803757), JX-0011C was withdrawn. References to that document in the parties’ briefs and in the hearing transcript should be assumed to refer to JX-0013C.

## PUBLIC VERSION

customers as competitors in the United States); CX-0501<sup>4</sup> (Li Dep.) at 35:22–25 (identifying Vego Garden as selling the same products as Utopban).

## II. JURISDICTION

### A. Statutory Jurisdiction

Congress has directed that “[t]he Commission shall investigate any alleged violation of this section on complaint under oath or upon its initiative.” 19 U.S.C. § 1337(b)(1). Section 337(a)(1)(A) declares unlawful, *inter alia*, “[u]nfair methods of competition and unfair acts in the importation of articles . . . the threat or effect of which is – (i) to destroy or substantially injure an industry in the United States . . . .” 19 U.S.C. § 1337(a)(1)(A). Such unfair methods of competition and unfair acts may include the importation of articles that incorporate misappropriated trade secrets. *Certain Rubber Resins and Processes for Mfg. Same*, Inv. No. 337-TA-849, Comm’n Op. at 9 (Feb. 26, 2014) (EDIS Doc. ID 528759) (*Rubber Resins*). They may also include the importation of articles that are falsely advertised under the Lanham Act, 15 U.S.C. § 1125(a)(1). *Certain Food Processing Equipment and Packaging Materials Thereof*, Inv. No. 337-TA-1161, Initial Determination at 14 (Feb. 18, 2020) (collecting cases) (EDIS Doc. ID 704184) (*Food Processing Equipment*), *unreviewed by*, Comm’n Notice (Apr. 3, 2020) (EDIS Doc. ID 707002). Pursuant to statute, therefore, the Commission has statutory authority to investigate complaints including allegations of trade secret misappropriation and false advertising with respect to articles imported into the United States.

---

<sup>4</sup> Complainant’s exhibit list indicates that CX-0501 was “admitted for limited purpose.” (EDIS Doc. ID 803737). This is inaccurate. In Order No. 24, (EDIS Doc. ID 796727), I allowed the parties to designate deposition testimony of the opposing party’s witnesses who would be testifying remotely. The designated testimony of Mr. Li was admitted for all purposes.

## PUBLIC VERSION

Respondents do not contest the statutory authority of the Commission to investigate Vego Garden's false advertising claim but do contest the authority of the Commission to investigate Vego Garden's trade secret misappropriation claim. Respondents Post-Hearing Br. at 6–7. Respondents assert that “the Commission has no jurisdiction over trade secret disputes that occurred in China.” *Id.* at 7.

As to Respondents' allegation that the Commission lacks jurisdiction, the Supreme Court has held that the concept of “subject matter jurisdiction” does not apply to administrative agencies. *Certain Video Security Equip. & Sys., Related Software, Components Thereof, & Prods. Containing Same*, Inv. No. 337-TA-1281, Comm'n Op. at 9–10 (Apr. 19, 2023) (EDIS Doc. ID 794569), *citing City of Arlington, Tex. v. FCC*, 569 U.S. 290, 297 (2013). The question, therefore, is the Commission's statutory authority to act, which is “is authoritatively prescribed by Congress.” *Id.* (internal quotations omitted).

Respondents contend that the “alleged trade secrets that are the basis of this Investigation are based exclusively in China – the alleged trade secrets were developed in China, the agreements being asserted are private contracts and nondisclosure agreements between Chinese companies, and the alleged unfair acts all occurred in China.”<sup>5</sup> Respondents Post-Hearing Br. at 6–7. Respondents ignore, however, their alleged importation into the United States of raised metal garden bed products improperly incorporating Vego Garden's trade secrets.

---

<sup>5</sup> Respondents' contention that all relevant activity occurs in China is belied by Green Giant's allegations in its Counterclaim, which seeks a declaratory judgment that it has not misappropriated any of Vego Garden's trade secrets. *See* Counterclaim, ¶¶ 46–54. Green Giant asserts that venue is proper in Texas “because a substantial part of the events giving rise to the Counterclaim occurred in this District.” Notice of Removal, ¶ 4 (EDIS Doc. ID 786930).

## PUBLIC VERSION

The unfair acts the Commission has statutory authority to investigate involve the importation into the United States of products incorporating misappropriated trade secrets. *TianRui Grp. Co. Ltd. v. Int’l Trade Comm’n*, 661 F.3d 1322, 1329–32 (Fed. Cir. 2011). In *TianRui*, the Federal Circuit considered and rejected the same argument Respondents make here, holding that “section 337 is expressly directed at unfair methods of competition and unfair acts ‘in the importation of articles’ into the United States” such that “the foreign ‘unfair’ activity [trade secret misappropriation] is relevant only to the extent that it results in the importation of goods into this country causing domestic injury.” *Id.* at 1329.

Though Respondents cite *TianRui*, they do not attempt to distinguish its holding and do not address Vego Garden’s allegations of importation with respect to the Commission’s statutory authority to investigate the trade secret misappropriation claim. Respondents Post-Hearing Br. at 6–7. Respondents instead contend that “it is reasonable to conclude that the Commission lacks jurisdiction in this Investigation as the allegedly infringed rights exist under the laws of China.” *Id.* at 7.<sup>6</sup> The Commission’s statutory authority, however, is not circumscribed in the way Respondents urge. Instead, the Commission has statutory authority to investigate the alleged importation of goods incorporating misappropriated trade secrets causing injury to a domestic industry.

Vego Garden alleges that the Respondents’ raised metal garden bed products, imported into the United States, include its misappropriated trade secrets, and have injured its domestic industry. Amended Complaint, ¶¶ 5.1–5.5 and Complainant Post-Hearing Br. at 21–32 and 43–45.

---

<sup>6</sup> To the extent Respondents argue that a Chinese entity owns “the allegedly infringed rights,” Vego Garden, a U.S. company, asserts that it owns the trade secrets allegedly misappropriated and owns the photographs underlying its false advertising claim. *See* sections VI.A and VIII.B, respectively.

## PUBLIC VERSION

As confirmed by the Federal Circuit in *TianRui*, I conclude that the Commission has statutory authority to investigate Vego Garden's trade secret misappropriation claim.

### **B. Personal Jurisdiction**

By filing a complaint and participating in this investigation, Vego Garden consented to the personal jurisdiction of the Commission. *See Certain Toner Cartridges, Components Thereof, and Systems Containing Same*, Inv. No. 337-TA-1174, Initial Determination at 34–35 (July 23, 2020) (EDIS Doc. ID 716848), *unreviewed by*, Comm'n Notice (Sept. 8, 2020) (EDIS Doc. ID 719096). Respondents Green Giant and Utopban both appeared and participated in this investigation, thus submitting themselves to the personal jurisdiction of the Commission.

I therefore conclude that the Commission has personal jurisdiction over complainant Vego Garden and respondents Green Giant and Utopban. *See, e.g., Certain Strontium-Rubidium Radioisotope Infusion Systems, and Components Thereof Including Generators*, Inv. No. 337-TA-1110, Initial Determination at 9 (Aug. 1, 2019) (EDIS Doc. ID 685112), *unreviewed in pertinent part by*, Comm'n Notice (Sept. 30, 2019) (EDIS Doc. ID 689653).

### **C. In Rem Jurisdiction**

The record evidence addressed in section IV demonstrates that the accused products have been imported into the United States. I therefore conclude that the Commission has *in rem* jurisdiction over the accused products in this investigation. *See Sealed Air Corp. v. Int'l Trade Comm'n*, 645 F.2d 976, 985–86 (C.C.P.A. 1981) (the Commission has jurisdiction over imported goods).



## PUBLIC VERSION

### III. STANDING

#### A. Standing to Assert Trade Secret Misappropriation

The party that owns or exclusively licenses alleged trade secrets has standing to assert misappropriation at the Commission. 19 C.F.R. § 210.12(a)(7). *Rubber Resins*, Inv. No. 337-TA-849, Initial Determination at 44 (Jun. 17, 2013) (EDIS Doc. ID 516322) (to have standing, “the Commission Rules require the complainant own the trade secrets at issue or be the exclusive licensee”); *Certain Cast Steel Ry. Wheels, Certain Processes for Mfg. or Relating to Same & Certain Products Containing Same*, Inv. No. 337-TA-655, Initial Determination at 17 (Oct. 16, 2009) (EDIS Doc. ID 414899), *unreviewed by*, Comm’n Notice (Dec. 17, 2009) (EDIS Doc. ID 416143) (complainant “has established that it owns the trade secrets asserted in this investigation, and that it has standing”); *Certain Activity Tracking Devices, Systems, and Components Thereof*, Inv. No. 337-TA-963, Order No. 55, at 4 (Apr. 27, 2016) (EDIS Doc. ID 579771) (complainants had standing where “there is no dispute that Complainants have possession and title to the asserted trade secrets”). As discussed in section VI.A, I find that Vego Garden owns the alleged trade secrets. I therefore conclude that Vego Garden has standing to assert trade secret misappropriation.

#### B. Standing to Assert False Advertising

The Supreme Court considered “the appropriate analytical framework for determining a party’s standing to maintain an action for false advertising under the Lanham Act” in *Lexmark Int’l, Inc. v. Static Control Components, Inc.*, 572 U.S. 118, 124 (2014). A plaintiff has a right to sue for false advertising under 15 U.S.C. § 1125(a) if they allege “an injury to a commercial interest in reputation or sales” and “economic or reputational injury flowing directly from the deception wrought by the defendant’s advertising.” *Id.* at 132 and 133.

## PUBLIC VERSION

Vego Garden alleges that it owns photographs forming the basis of its false advertising claim. Complainant Post-Hearing Br. at 35; *see also* CX-0064; CX-0065; CX-0066; CX-0068; CX-0069; CX-0072; and CX-0074. Respondents do not dispute that Vego Gardens owns the photographs. Tr. (Li) at 312:11–313:11. Vego Garden alleges injuries of lost revenue and damage to its business reputation because Utopban used its photographs to advertise Respondents’ products, which “are injuries to precisely the sorts of commercial interests the [Lanham] Act protects.” 572 U.S. at 137; Complainant Post-Hearing Br. at 44. I therefore conclude that Vego Garden has standing to assert false advertising under 15 U.S.C. § 1125(a)(1).

#### IV. IMPORTATION

Section 337 prohibits “[u]nfair methods of competition and unfair acts in the importation of articles . . . into the United States, or in the sale of such articles by the owner, importer, or consignee, the threat or effect of which is—[] to destroy or substantially injure an industry in the United States. . . .” 19 U.S.C. § 1337(a)(1)(A)(i). A single importation of an accused product is sufficient to satisfy the importation requirement of section 337. *Certain Trolley Wheel Assemblies*, Inv. No. 337-TA-161, USITC Pub. No. 1605, Comm’n Op. at 7–8 (Nov. 1984) (deeming the importation requirement satisfied by the importation of a single product of no commercial value) (EDIS Doc. ID 235418).

The evidence demonstrates that the accused raised metal garden beds are manufactured by Green Giant, sold for importation into the United States by Green Giant, and imported into and then sold in the United States by Utopban. Tr. (Lu) at 335:1–5 (Green Giant manufactures raised garden beds and accessories but does not import them directly into the United States); CX-0500 (Lu. Dep.) at 54:5–15 (Green Giant sells its raised garden bed products to Utopban, which resells them in the United States) and at 57:2–58:8 (testifying about sales summary identifying Green

## PUBLIC VERSION

Giant sales of raised garden bed products to Vegega (Utopban)); JX-0044 (Green Giant sales summary); Tr. (Li) at 326:4–18 (Utopban is the importer of record for raised metal garden bed products imported into the United States) and 329:3–15 (Utopban imports raised metal garden bed products manufactured by Green Giant into the United States); CX-0081C (Utopban sales summary); CX-0501 (Li Dep.) at 25:10–12 and 26:5 (Utopban is the importer of record for raised metal garden bed products imported into the United States); and Exhibit A to Utopban Response to Complaint, ¶ a (“The quantity of Utopban Limited’s accused products imported into the US in the year prior to filing this response on December 5, 2022, is 5350.”).

Based on the record evidence, I conclude that the accused raised metal garden bed products have been imported into the United States.

### V. WHETHER THERE ARE PROTECTABLE TRADE SECRETS

Section 337(a)(1)(A)(i) prohibits “[u]nfair methods of competition and unfair acts in the importation of articles . . . into the United States, or in the sale of such articles by the owner, importer, or consignee . . . .” 19 U.S.C. § 1337(a)(1)(A)(i). One unfair method of competition cognizable under Section 337(a)(1)(A) is misappropriation of trade secrets. *Rubber Resins, Inv. No. 337-TA-849, Comm’n Op. at 9.*

Trade secret misappropriation is defined by the common law. *Id.* A single federal standard, rather than the law of a particular state, applies. *TianRui*, 661 F.3d at 1327. Sources for this federal standard include the Restatement of Unfair Competition, the Uniform Trade Secrets Act (UTSA), the Restatement of Torts, the Defend Trade Secrets Act of 2016 (18 U.S.C. §§ 1831-39), and federal common law. *Certain Bone Cements, Components Thereof, and Products Containing the Same, Inv. No. 337-TA-1153, Comm’n Op. at 6 (Jan. 25, 2021) (EDIS Doc. ID 731649) (Bone Cements).* The elements of trade secret misappropriation of are:

## PUBLIC VERSION

(1) the existence of a process that is protectable as a trade secret (*e.g.*, that is (a) of economic value, (b) not generally known or readily ascertainable, and (c) that the complainant has taken reasonable precautions to maintain its secrecy);

(2) the complainant is the owner of the trade secret;

(3) the complainant disclosed the trade secret to respondent while in a confidential relationship or that the respondent wrongfully took the trade secret by unfair means; and

(4) the respondent has used or disclosed the trade secret causing injury to the complainant.

*Rubber Resins*, Inv. No. 337-TA-849, Comm'n Op. at 10, *citing Certain Processes for the Manufacture of Skinless Sausage Casings & Resulting Prod.*, Inv. Nos. 337-TA-148/169, USITC Pub. No. 1624, Initial Determination at 244, *unreviewed in pertinent part* (Dec. 1984) (EDIS Doc. ID 235421) (*Sausage Casings*); UTSA, § 1(4).

The existence of a trade secret is a prerequisite for a trade secret misappropriation claim. *Rubber Resins*, Inv. No. 337-TA-849, Comm'n Op. at 10, *citing Sausage Casings*, Initial Determination at 244. The complainant bears the burden of showing “the existence of a process that is protectable as a trade secret.” *Id.* at 56–59. “The common law does not provide ‘precise criteria for determining the existence of a trade secret,’ but instead requires ‘a comparative evaluation of all the relevant factors, including the value, secrecy, and definiteness of the information as well as the nature of the defendant’s misconduct.’” *Certain Activity Tracking Devices, Sys., & Components Thereof*, Inv. No. 337-TA-963, Initial Determination at 18 (Aug. 23, 2016) (EDIS Doc. ID 591157), *quoting* Restatement (Third) of Unfair Competition § 39 cmt. d., *unreviewed by*, Comm'n Notice (Oct. 20, 2016) (EDIS Doc. ID 593177) (*Activity Trackers*). The applicable common law rule is found in the Restatement, which provides that “[a] person claiming rights in a trade secret bears the burden of defining the information for which protection is sought

## PUBLIC VERSION

with sufficient definiteness to permit a court to apply the criteria for protection described in this Section [i.e., value and secrecy], and to determine the fact of an appropriation.” Restatement § 39 cmt. d. A broad trade secret may nevertheless be protectable when “the details set forth in the [asserted trade secret] are sufficiently specific to warrant trade secret protection because they distinguish the trade secret from what was generally known in the industry.” *See Certain Crawler Cranes and Components Thereof*, Inv. No. 337-TA-887, Comm’n Op. at 45–46 (May 6, 2015) (EDIS Doc. ID 556530) (*Crawler Cranes*).

The Commission looks to the following six factors—each of which relates to issues of value and/or secrecy—to determine whether a trade secret exists:

1. the extent to which the information is known outside of complainant’s business;
2. the extent to which it is known by employees and others involved in complainant’s business;
3. the extent of measures taken by complainant to guard the secrecy of the information;
4. the value of the information to complainant and to his competitors;
5. the amount of effort or money expended by complainant in developing the information; and
6. the ease or difficulty with which the information could be properly acquired or duplicated by others.

*Sausage Casings*, Inv. Nos. 337-TA-148/169, Initial Determination at 245–246, *citing* Restatement of Torts § 757, cmt. b. These factors are “instructive guidelines,” not a six-pronged test. *See Crawler Cranes*, Inv. No. 337-TA-887, Initial Determination at 24 (Jul. 11, 2014) (EDIS Doc. ID 539295).

Considering the *Sausage Casings* factors, I first consider whether there are any protectable trade secrets.

## PUBLIC VERSION

### A. Vego Garden's Identification of the Asserted Trade Secrets

Vego Garden asserts three trade secrets: (1) research and development of an 8-inch raised metal garden bed in various configurations, which it refers to as its product development research trade secret; (2) research and selection of the film used to protect its raised metal garden bed products during manufacture and transit, which it refers to as its product materials research trade secret; and (3) development and implementation of improvements to the manufacturing equipment used to bend corrugated metal and generate the corner panels of its raised metal garden beds, which it refers to as its product manufacturing trade secret. Complainant Post-Hearing Br. at 10–15.

Respondents argue that “Complainant has failed to even coherently define the information alleged to be a trade secret in this Investigation.” Respondents Post-Hearing Br. at 7; and Respondents Post-Hearing Resp. Br. at 6. The Staff contends that Respondents waived this argument by failing to raise it in their pre-hearing brief. Staff Post-Hearing Br. at 12; *see also* Staff Post-Hearing Resp. Br. at 1. I agree that Respondents waived this issue because it was not raised in their pre-hearing brief. *See* Respondents Pre-Hearing Br. at 6–7; and Order No. 14 (Ground Rules) at 11.2.

Nonetheless, in belatedly contending that Vego Garden failed to identify the alleged trade secrets with specificity, Respondents cite multiple times to “*Kuryakyn* at 798–800,” arguing that it supports Respondents’ contention that Vego Garden’s description of its alleged trade secrets “fails to identify which aspects are known to the trade and which are not.” Respondents Post-Hearing Br. at 8–9. Respondents are presumably referencing *Kuryakyn Holdings, LLC v. Ciro LLC*, 242 F. Supp. 3d 789 (W.D. Wis. 2017). In granting summary judgment there, the district court stated that it could not determine whether the alleged trade secrets met the statutory requirements because the plaintiff “fail[ed] to pin down the purported trade secrets.” 242 F. Supp.

## PUBLIC VERSION

3d at 799. In reaching that conclusion, the court noted the descriptions of the trade secrets such as, “information about [the] manufacturing skill, reliability, resources, capacity, technological knowledge, costs of manufacture, component costs, and expertise specific to the development and production of motorcycle parts and accessories,” “[i]nformation about [its] development of a smartphone app for controlling colored lights applied to motorcycles,” and the “concept and design” of its smartphone app. *Id.*

The trade secret descriptions here are far more specific than the general descriptions in *Kuryakyn* and allow “meaningful comparison of the putative trade secret information with information that is generally known and ascertainable in the relevant field or industry.” *Activity Trackers*, Inv. No. 337-TA-963, Initial Determination at 17. I therefore agree with the Staff and Vego Garden that each of the alleged trade secrets was identified with the required specificity. *See* Staff Post-Hearing Br. at 11–12; Complainant Pre-Hearing Br. at 7–9 (EDIS Doc. ID 795228).

Respondents also argue that by relying on the testimony of Mr. Xiong, Vego Garden’s founder and CEO, Tr. 24:25–25:2 and 98:12–13, Vego Garden has not met its burden of proof in establishing the existence of any trade secrets. Respondents Post-Hearing Resp. Br. at 1. As support for this proposition, Respondents quote that a “complainant . . . must come forward with reliable, probative, and substantial evidence.” *Id.*, quoting *Certain Trolley Wheel Assemblies*, Inv. No. 337-TA-161, Order No. 8, 1984 WL 273875 (Feb. 23, 1984). There, however, whether testimony was sufficient was not an issue. Instead, there the Administrative Law Judge granted in part a motion for sanctions after the respondents, which had not appeared in the investigation, failed to respond to discovery requests. *Id.* at \*2. In response to an argument that no evidence supported a particular proposition, the Commission has recognized that “testimony is evidence.” *Certain Child Carriers and Components Thereof*, Inv. No. 337-TA-1154, USITC Pub. No. 1154,

## PUBLIC VERSION

Initial Determination at 67–68, *unreviewed in pertinent part by Comm’n Notice* (Feb. 2022) (EDIS Doc. ID 766202). The question, therefore, is whether, considering the record as a whole, Vego Garden has established the existence of trade secrets, including testimonial evidence.

### **B. Identification of the Involved Entities**

Vego Garden does not manufacture its raised metal garden bed products and instead relies on a Chinese manufacturer, Shun Chuen, to manufacture its products. Tr. (Xiong) at 49:7–8. Mr. Yu is an engineer who was employed by Shun Chuen and was Vego Garden’s point of contact at Shun Chuen. *See id.* at 49:10–12. Shun Chuen in turn relies on metal material supplied by Foshan Nahong, which produces metal coil used by Shun Chuen to manufacture Vego Garden’s raised garden beds. *See id.* at 51:16–52:4. Mr. Lu, the founder and general manager of Green Giant, Tr. (Lu) 334:14–24, previously worked for Foshan Nahong. Counterclaim, ¶ 7. Vego Garden and Shun Chuen also worked with Foshan Baoshuo Intelligent Equipment Manufacturing Co., Ltd. (Baoshuo), which is a factory that made the bending machine Shun Chuen uses to manufacture Vego Garden’s raised metal garden beds. Tr. (Xiong) at 205:8–15.<sup>7</sup>

### **C. The Asserted 8-Inch Product Development Trade Secret**

Vego Garden’s 8-inch product development trade secret consists of research and planning undertaken by it to develop and bring to market an 8-inch raised metal garden bed product line. Complainant Post-Hearing Br. at 10–12; Staff Post-Hearing Br. at 15; and Tr. (Xiong) at 57:24–59:18.

---

<sup>7</sup> Shun Chuen is often referred to in the hearing transcript as SC. Tr. (Xiong) at 30:9–15; Foshan Nahong is often referred to in the hearing transcript as FN. Tr. (Xiong) at 51:14–52.5; and Foshan Baoshuo is often referred to in the hearing transcript as FB. Tr. (Xiong) at 205:8–12.



## PUBLIC VERSION

### 1. Extent the Trade Secret Was Known Outside Vego Garden

Vego Garden contends that its 8-inch product development trade secret was not generally known outside of Vego Garden. Complainant Post-Hearing Br. at 22. The Staff agrees that Respondents have not shown that 8-inch garden beds were known in the industry before Green Giant began selling its 8-inch raised garden beds. *See* Staff Post-Hearing Br. at 16–17.

Mr. Xiong testified that Vego Garden spent roughly a year investigating customer sentiment, performing market research, and analyzing manufacturing and marketing costs before launching its 8-inch product line. *See* Tr. (Xiong) at 58:15–59:6. Mr. Xiong further testified that no other competitor was offering an 8-inch product when Vego Garden began considering it, *id.* at 58:10–13, and that Vego Garden only disclosed this information outside of Vego Garden to its manufacturer Shun Chuen. *See id.* at 59:16–18; Complainant Post-Hearing Br. at 11, 22; *see also* SX-0005C.007-009 (Vego Garden’s Supp. Resp. to the Staff’s First Set of Interrogatories).

Before Vego Garden offered an 8-inch product on the market, Respondents did. The evidence shows that, before Utopban offered Green Giant’s 8-inch product line for sale in the United States, no other raised metal garden bed product of this height was available in the market. Mr. Li, Utopban’s corporate representative, testified as follows:

Q. Mr. Li, before the break, one of the issues we talked about was the 8-inch type garden bed.

And did Utopban Limited do any type of research to determine whether an 8-inch market – or, excuse me, an 8-inch height garden bed would be acceptable to the market?

A. I don’t – I didn’t do any market research, but – because manufacturer [Green Giant] told me that they have this product available. And then, for me, I realize that this product was also not available in the market.

CX-0501 (Li Dep.) at 44:24–45:9; *see also id.* at 83:5–9 (Green Giant is the only manufacturer from which Utopban obtains raised metal garden bed products).

## PUBLIC VERSION

Respondents contend that “Mr. Li testified that the reason he stated no 8” raised garden beds in the market prior to Utopban’s entry of the market is that he did not do any research on this product.” Respondents Post-Hearing Br. at 16, *citing* Tr. (Li) at 330:7–9. Mr. Li may have done no “research,” but he unambiguously testified at his deposition that an 8-inch product was “not available in the market.” CX-0501 (Li Dep.) at 44:24–45:9. Respondents’ attempt to explain away Mr. Li’s testimony is unpersuasive.

Respondents also contend that “raised garden bed products with lower height are known in the industry” and that searching on the internet “will reveal lower height raised garden bed as well as tree ring with similar heights.” Respondents Post-Hearing Br. at 12; *see also* Respondents Post-Hearing Resp. Br. at 7–9. Respondents cite (without reference to any specific pages) to a document that is a collection of website information prepared by Mr. Lu, the founder of Green Giant, purporting to show availability in the market of various raised metal garden bed products. Respondents Post-Hearing Br. at 12; RX-0004; and Tr. (Lu) at 361:18–362:1 (Mr. Lu prepared RX-0004). This collection of information, however, does not include any information about or an image of an 8-inch raised metal garden bed product, nor does it otherwise show that an 8-inch raised metal garden bed product was known before Utopban launched its 8-inch product. *See generally* RX-0004. For example, RX-0004 includes the following image, apparently a YouTube screenshot:

# PUBLIC VERSION

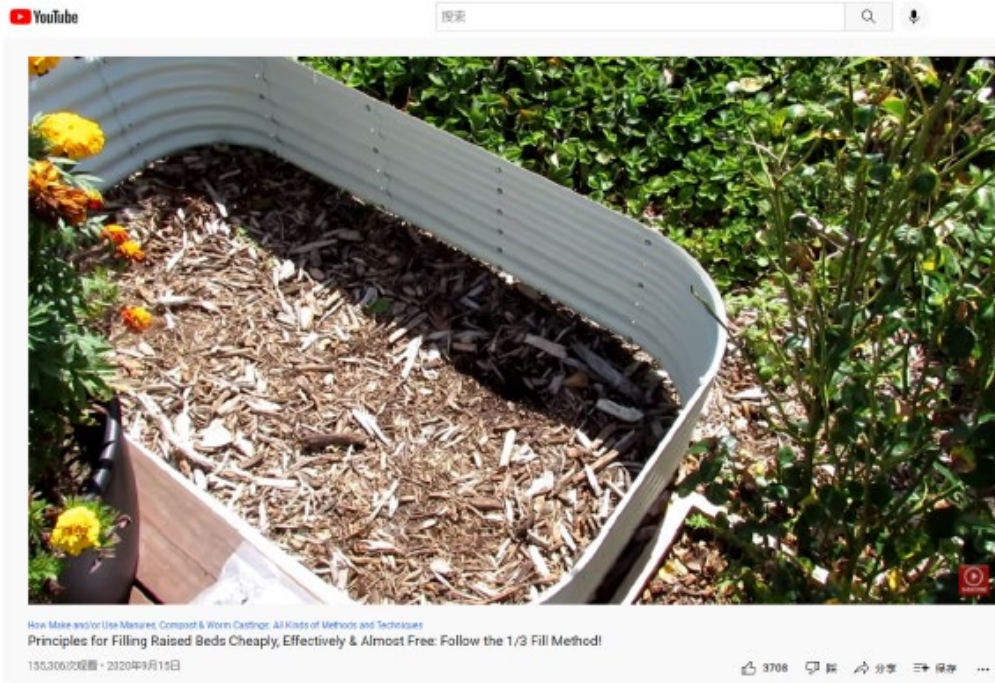

RX-0004 at 32.

While this is a picture of a raised metal garden bed, with a date of September 15, 2020, its height is not disclosed and appears to be greater than eight inches.

RX-0004 also includes images of an 8-inch tree ring, such as the following:

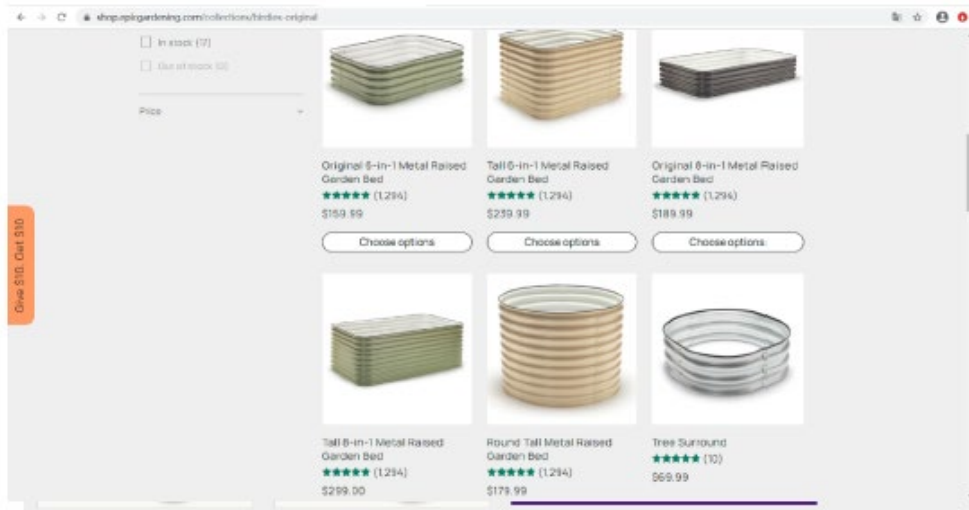

RX-0004 at 24.

## PUBLIC VERSION

There is no date provided for this screenshot, which is apparently from the website <https://shop.epicgardening.com/collections/birdies-original>, RX-0004 at 24, and thus it does not support that an 8-inch product was known before Utopban's introduction of Green Giant's 8-inch product. Respondents do not cite any information in RX-0004 suggesting that an 8-inch product was known before Utopban introduced its 8-inch product to the market. *See* Respondents Post-Hearing Br. at 12.

Respondents also argue that “there were ample public information about lower garden beds on the market” including raised metal garden beds and tree rings. Respondents Post-Hearing Resp. Br. at 9, additionally citing RX-0015, RX-0017, RX-0057, and RX-0059; *see also* Respondents Post-Hearing Resp. Br. at 8. None of the documents cited by Respondents, however, disclose an 8-inch raised metal garden bed product. RX-0015 is U.S. Patent Publ. No. 2015/0233405, which discloses, at most, a modular garden bed having a maximum height of less than 75 cm (30 inches). *See* RX-0015 at [0020]. RX-0017 is U.S. Patent Publ. No. 2012/0096766, which discloses a modular garden bed but lacks any description as to its height. *See generally* RX-0017. RX-0057 and RX-0059 appear to be screenshots of YouTube videos for Birdie's Raised Garden Beds, neither of which discloses an 8-inch raised metal garden bed product.

Respondents also contend that Vego Garden's sale of an 8-inch tree ring publicly disclosed its 8-inch product development trade secret. Respondents Post-Hearing Br. at 13. Mr. Xiong testified, however, that Vego Garden only launched its 8-inch tree ring product<sup>8</sup> in February 2023,

---

<sup>8</sup> Vego Garden has not distinguished a tree ring product from a raised metal garden bed and Respondents appear to argue that a tree ring is a type of raised metal garden bed. Respondents Post-Hearing Br. at 12–13; Respondents Post-Hearing Resp. Br. at 10; and Tr (Xiong) at 193:1–12 (testifying that tree rings can be used as raised metal garden beds and are sold “under the raised garden bed parent menu.”) Thus, in considering whether Vego Garden's 8-inch product

## PUBLIC VERSION

after Utopban first offered Green Giant’s 8-inch raised metal garden bed product in around the first quarter of 2022. *See* Tr. (Xiong) at 59:21–60:2 (Vego Garden offered its 8-inch tree ring product in February 2023)<sup>9</sup>, CX-0019 at VEGO-ITC-00164-166 (Green Giant catalog showing 8-inch product); Tr. (Lu) at 358:12–25 (Green Giant introduced 8-inch product); CX-0501 (Li Dep.) at 29:24–30:13 (Utopban offered an 8-inch product in around the first quarter of 2022). In addition, while Utopban’s sale of 8-inch raised metal garden beds publicly disclosed Vego Garden’s alleged trade secret, Vego Garden contends that Respondents were only able to launch such a product because of misappropriation of its trade secret. Complainant Post-Hearing Br. at 10–12.

Respondents also note that Mr. Lu testified that 8-inches was a standard size available on the market and that the reason Green Giant manufactured an 8-inch product was because its machine could do so. Respondents’ Post-Hearing Resp. Br. at 9, *citing* Tr. (Lu) at 358:15–20; 356:23–358:11; 356:23–357:5 and 15–24. This testimony from Mr. Lu, however, is not credible because there is no evidence that 8-inch products were known or “standard” before Respondents introduced them to the market. If 8-inch products were standard, there would be some evidence that they previously existed in the market. There is not.<sup>10</sup>

---

development trade secret was known outside of Vego Garden, I have considered whether any such product was known, whether called a raised garden bed or a tree ring.

<sup>9</sup> Respondents contend that Vego Garden launched its 8-inch product “at earliest in December 2022 as there was already customers’ review on Complainant’s website.” Respondents Post-Hearing Resp. Br. at 10. Respondents cite no evidence supporting this assertion. In addition, the relevant point is that Vego Garden offered its 8-inch product to the market *after* Respondents. This does not appear to be disputed by Respondents.

<sup>10</sup> Respondents also argue that “Green Giant’s 8-inch product is not really an 8-inch” product because it measures 7.87 inches. Respondents’ Post-Hearing Resp. Br. at 9 and n.4. To the extent Respondents are arguing that their products do not incorporate Vego Garden’s trade secret because they measure slightly less than 8 inches, Respondents did not raise that issue in their pre-hearing brief, and thus waived it. *See* Respondents Pre-Hearing Br. at 16–19; and Order No. 14 (Ground

## PUBLIC VERSION

The evidence shows that the 8-inch product development trade secret was not generally known outside Vego Garden until Respondents introduced such a product onto the market.

### **2. Extent All Trade Secrets Were Known Inside Vego Garden**

Vego Garden contends that it has taken significant steps to protect its confidential information, including: (1) employment handbooks identifying employee confidentiality obligations; (2) segregating access to trade secret information based on an employee's role at the company; (3) storing trade secret information in network storage folders and limiting access to such folders; (4) user-level access limitation to electronic files in its computer system; (5) password-protected electronic files; (6) location of physical files in locked cabinets with limited access; (7) key card access restriction to areas in Vego Garden's offices with trade secret information, and (8) termination of access by former Vego Garden employees to electronic files and equipment upon separation from the company. Tr. (Xiong) at 69:5–71:2 (Mr. Xiong explaining Vego Garden's security measures); JX-0016 (Vego Garden September 2020 Employee Handbook at section 5–9, addressing protection of company confidential information); JX-0018 (Vego Garden October 2022 Employee Handbook at section 6-13, addressing protection of company confidential information); and SX-0002C.011–12 (responses to Staff interrogatories). The Staff agrees that Vego Garden has implemented sufficient measures within the company to protect its confidential information. Staff Post-Hearing Br. at 17–20.

---

Rules) at 11.2. Further, Mr. Li testified that he rounded up to 8-inches “to be convenient.” The evidence supports that as a matter of nomenclature, Respondents' product is an 8-inch product although it may measure slightly less than that. Tr (Li) at 313:18–22. Indeed, Mr. Lu, testifying about RDX-0002 (identifying a height of 7.87 inches in Figure C), confirmed that an 8-inch product was shown, contrary to Respondents' argument. Tr. (Lu) at 356:18–357:5.

## PUBLIC VERSION

Respondents contend that Vego Garden did not adequately internally protect its confidential information. Respondents Post-Hearing Br. at 13. Respondents rely on the testimony of Mr. Xiong and allege that “he only testified that [Vego Garden’s] computers are password protected” and not individual files. *Id.*, citing Tr. (Xiong) at 70:13–14. A fair reading of Mr. Xiong’s testimony, however, does not support Respondents’ assertion. Mr. Xiong testified that, “we have all the employees -- in the employee handbook we emphasize the confidential and how important it is, and we limit access of information we have to the employees.” Tr. (Xiong) at 69:9–12. Mr. Xiong also testified that, even within Vego Garden, access to confidential information was only provided on a need-to-know basis: “[d]ifferent employees have different access to different folders, and we limit their access, only give the information that -- they have to have access in order to perform their work.” *Id.* at 70:9–12. Further, Mr. Xiong testified at the hearing that employees use key cards to access Vego Garden’s facilities, and Vego Garden disables all access to confidential information immediately upon an employee’s separation from the company. *Id.* at 70:15–71:2.

The evidence thus demonstrates that Vego Garden employees each have electronic access to the specific information that need for their job. Information is stored on a secure server, access to the network storage folders is limited, and any physical file containing Vego Garden’s trade secret information is maintained in a locked cabinet, accessible only by those who have a need to know such information. SX-0002C.011–012 (Vego Garden’s Resp. to the Green Giant’s First Set of Interrogatories). Areas in Vego Garden’s offices where any file containing Vego Garden’s trade secrets are further restricted to those who have a key card, allowing access to such areas. Tr. (Xiong) at 70:15–20, SX-0002C.011-012; *see also* SX-0005C.007–008 (Vego Garden’s Supp. Resp. to the Staff’s First Set of Interrogatories).

## PUBLIC VERSION

Respondents also assert that Vego Garden did not internally protect its own information because it “shared the same employees with Worldlink and G&A partners.” Respondents Post-Hearing Br. at 13; *see also* Respondents Post-Hearing Resp. Br. at 11–12. Mr. Xiong testified that Worldlink is the predecessor company to what is now known as Vego Garden. Tr. (Xiong) at 25:12–22 (Worldlink made first sales of raised metal garden beds), 94:7–19 (Worldlink is Vego Garden’s predecessor); 95:5–12 (Worldlink employees became Vego Garden employees and has the same address), 95:18–22 (“[Worldlink is] the same group of people. And it is correct to say that Worldlink is part of Vego Garden.”). As such, the Worldlink (now Vego Garden) employees would have been subject to the confidentiality terms set forth in the September 2020 version of Vego Garden’s Employee Handbook (as well as all successor versions of the Handbook) as well as the other measures to maintain secrecy. JX-0016 (Vego Garden Employee Handbook (Sept. 2020)) at 22.

As to G&A Partners, the evidence shows that this entity is “a Professional Employer Organization” “responsible for administration of payroll, workers’ compensation, and benefits (if sponsored by G&A), federal and state unemployment insurance and certain human resources functions not performed by Vego Garden Inc.” JX-0016 at 2; *see also* JX-0018 (Vego Garden Employee Handbook (Oct. 2022)) at 2. There is no evidence that G&A Partners ever shared employees with Vego Garden, as Respondents assert.<sup>11</sup> In addition, there is no evidence that G&A Partners ever had access to any Vego Garden trade secret information.

---

<sup>11</sup> Respondents contend that the “Staff’s argument that the shared employees with G&A Partners highly unlikely has access to the alleged trade secrets, and there is no evidence suggesting such access is an attorney argument.” Respondents Post-Hearing Resp. Br. at 12. To the extent this argument is understood, the evidence does not support that Vego Garden shared employees with G&A Partners and does not support that Vego Garden shared any trade secret information with



## PUBLIC VERSION

The evidence supports that Vego Garden took appropriate steps to guard all of its asserted trade secret information within the company.

### 3. Steps Taken By Vego Garden to Protect the Trade Secret

Vego Garden disclosed its 8-inch product development trade secret to its manufacturer, Shun Chuen. Tr. (Xiong) at 59:16–18 and 74:7–9. The evidence demonstrates that Vego Garden and Shun Chuen entered into a mutual confidentiality agreement in April 2022 by which Shun Chuen agreed to maintain the confidentiality of Vego Garden’s information. JX-0020 at VEGO-ITC004289.<sup>12</sup> The agreement identifies a wide array of information as confidential. *Id.* at VEGO-ITC004287. Respondents do not dispute the validity or scope of this agreement, instead arguing that information disclosed by Vego Garden to Shun Chuen was not adequately protected before the April 2022 execution of the agreement. Respondents Post-Hearing Br. at 14. Mr. Xiong testified that there was an oral agreement in place between Vego Garden and Shun Chuen before execution of the written agreement in April 2022. Tr. (Xiong) at 71:15–20. Mr. Xiong testified that at the start of the collaboration between the companies, he spoke with Mrs. Xiong<sup>13</sup> of Shun

---

G&A Partners. The fact that G&A Partners performs purely administrative (payroll, workers’ compensation, and benefits) functions supports that it did not and would not receive trade secret information. Respondents’ arguments to the contrary are baseless. JX-0016 and JX-0018.

<sup>12</sup> Respondents contend that “Mr. Xiong only asked for Shun Chuen’s internal procedures relating to trade secret protection after the imitation [sic, institution] of this Investigation.” Respondents Post-Hearing Br. at 15, *citing* Tr. (Xiong) at 168:13–18. There, Mr. Xiong testified that there was a mutual confidentiality understanding with Shun Chuen and that “later on [Vego Garden] decided to put it in writing because of this legal case.” The confidentiality agreement between Vego Garden and Shun Chuen has an effective date in April 2022. JX-0020. The complaint in this investigation was not filed until September 2022. Moreover, even if the written confidentiality agreement was executed with an eye toward litigation, that does not refute either that agreement or that there was an oral agreement between the parties before that.

<sup>13</sup> Mr. Xiong testified that Mrs. Xiong is a remote relative, with the same family name. Tr. (Xiong) at 189:20–190:5.

## PUBLIC VERSION

Chuen about the collaboration and emphasized that it was a confidential project and that only certain people would have access to it. Tr. (Xiong) at 189:10–17.

An oral confidentiality agreement may be a reasonable measure to guard secrecy. *Learning Curve Toys, Inc. v. PlayWood Toys, Inc.*, 342 F.3d 714, 725–26 (7th Cir. 2003). This is true here, where the business relationship between Vego Garden and Shun Chuen as client/manufacturer, supports that Vego Garden’s confidential information would be maintained as secret by Shun Chuen. Further, the entities here are small and relatively unsophisticated, further supporting that Vego Garden’s oral confidentiality agreement with its manufacturer Shun Chuen was appropriate under the circumstances.

Respondents dispute the existence of an oral agreement by arguing that Mr. Xiong did not remember if there was any written record of the oral agreement. Respondents Post-Hearing Br. at 14–15. Whether there was a written record of an oral agreement, however, is beside the point. Mr. Xiong was clear that from the beginning of Vego Garden’s relationship with Shun Chuen, the parties understood that Shun Chuen would maintain the confidentiality of Vego Garden’s information. Tr. (Xiong) at 189:13–21. While Respondents contend that there is no testimony or evidence regarding whether anyone at Shun Chuen agreed to keep Vego Garden’s information confidential, the unambiguous testimony of Mr. Xiong, the nature of the relationship between Vego Garden and Shun Chuen, and the later execution of the written confidentiality agreement each support that there was an oral agreement with Shun Chuen to maintain the confidentiality of Vego Garden’s information.

Respondents also contend that “Mr. Xiong then offered contradict[ary] testimony that the alleged mutual understanding was between CEO from Shun Chuen who was not at Shun Chuen.” Respondents Post-Hearing Br. at 15, *citing* Tr. (Xiong) at 169:2–10. There, however, Mr. Xiong

## PUBLIC VERSION

explained that a different person at Shun Chuen, its general manager (not Mrs. Xiong) also understood that there was an oral confidentiality understanding between the companies and that there was a delay in executing a written agreement at least in part due to COVID. Tr. (Xiong) at 169:2–10. There is nothing inconsistent in Mr. Xiong’s testimony and there is nothing anomalous in the fact that at least two people at Shun Chuen understood the company had a confidential relationship with Vego Garden.

Respondents also question Mr. Xiong’s testimony about the location of Shun Chuen’s general manager and why he could not sign a confidentiality agreement before April 2022. Respondents Post-Hearing Resp. Br. at 12. Mr. Xiong was clear, however, that the general manager of Shun Chuen was not available to sign the agreement. And whether the April 2022 agreement could have been signed earlier does not change that the evidence supports the existence of an oral confidentiality agreement beginning when Vego Garden and Shun Chuen started working together.

Respondents also contend that “[n]ot surprisingly, the meeting minute produced by Vego dated June 8, 2021 is further contradicted with the alleged oral agreement as it is not marked as confidential or proprietary,” pointing to CX-0032. Respondents Post-Hearing Br. at 15. The fact that a single meeting minutes document is not labeled as confidential, however, is not dispositive and, in fact, is not especially meaningful. Moreover, Respondents do not contend that this particular document contains any confidential or trade secret information.

Relying on testimony from their expert, Respondents also appear to contend that non-disclosure agreements and confidential markings are required, or trade secret protection is lost. Respondents Post-Hearing Br. at 15–16; *see also* Respondents Post-Hearing Resp. Br. at 12–13. This is wrong. Instead, what is required is that Vego Garden took reasonable steps to guard the

## PUBLIC VERSION

secrecy of its information. Tr. (Phillips) at 453:11–17 (Respondents’ expert confirming that reasonable steps are required to maintain secrecy). Whether reasonable steps were taken is considered based on the particular circumstances, including the industry at issue and the size and sophistication of the parties. *Learning Curve*, 342 F.3d at 726.

Respondents also cite several cases for the propositions that “an implied contract of confidentiality” is insufficient and an “alleged duty of loyalty ‘does not somehow transform . . . freely-shared information into a *secret*.’” Respondents Post-Hearing Br. at 16, *citing Investment Science, LLC v. Oath Holdings Inc.*, 2021 WL 3541152 (S.D.N.Y. Aug. 11, 2021); and *Zabit v. Brandometry*, 540 F. Supp. 3d 412 (S.D.N.Y. 2021). Here, however, there is no implied contract of confidentiality and no alleged duty of loyalty. Instead, the evidence demonstrates that Vego Garden and its manufacturer entered into an oral confidentiality agreement at the beginning of their relationship and later entered into a written confidentiality agreement. What is reasonable with respect to confidentiality is case-specific. In appropriate circumstances, such as this one, an “express agreement [is] not necessary where the actions of the parties, the nature of their arrangement, the ‘whole picture’ of their relationship established the existence of a confidential relationship.” *Daniels Health Sciences, LLC v. Vascular Health Sciences, L.L.C.*, 710 F.3d 579, 584 (5th Cir. 2013).

Respondents also cite cases for the proposition that a signed confidentiality agreement standing alone is not sufficient to confer trade secret status on any underlying information. Respondents Post-Hearing Br. at 16, *citing Universal Processing LLC v. Weile Zhuang*, 2018 WL 4684115 (S.D.N.Y. Sept. 28, 2018); and *Elsevier Inc. v. Doctor Evidence, LLC*, 2018 WL 557906 (S.D.N.Y. Jan. 23, 2018). That, however, is beside the point. Vego Garden has not argued that the fact of a confidential relationship or agreement renders its information trade secret.

## PUBLIC VERSION

The evidence supports that Vego Garden took reasonable precautions to protect its 8-inch product development trade secret.

### **4. Value of the Trade Secret to Vego Garden and Competitors**

A trade secret “derives independent economic value, actual or potential, from not being generally known to, and not being readily ascertainable by proper means by, other persons who can obtain economic value from its disclosure or use.” Uniform Trade Secrets Act (UTSA) §1(4); *Activity Trackers*, Inv. No. 337-TA-963, Initial Determination at 18. In addition, there can be significant economic value to having a competitive head start and introducing a new product to the market. *Crawler Cranes*, Inv. No. 337-TA-887, Initial Determination at 145; *see* Staff Post-Hearing Br. at 20.

Vego Garden argues that the value to any competitor in the raised metal garden bed industry of being the first to market is significant, as customers in this market are reluctant to use multiple branded raised metal garden beds in their gardens. Complainant Post-Hearing Br. at 24. Vego Garden also contends that Respondents obtained that benefit because they were first to market with an 8-inch product. Respondents argue that Complainant did not provide evidence showing that its 8-inch product development trade secret provided a competitive advantage, whether or not Vego Garden would have been first to the market. Respondents Post-Hearing Br. at 17.

The evidence shows that Vego Garden’s research and development concerning an 8-inch product line, including a market need based on discussions with customers, likely afforded Vego Garden a competitive advantage. Tr. (Xiong) at 47:8–22, 57:24–58:12. Over approximately a one-year period, Vego Garden engaged in research and development regarding the viability and designs for the 8-inch height market, which supported Vego Garden’s decision to move into this market,

## PUBLIC VERSION

when possible, with current production demands. *Id.* at 58:13–59:13. In particular, Vego Garden collected customer feedback about the price point and preferences. *See id.* This market research led Vego Garden to conclude that it could capture a submarket for its raised metal garden beds if it could reduce the product’s price by reducing its height. *See id.*

In addition, Utopban’s corporate representative, Mr. Li, testified that there was value to being the only player on the market to offer an 8-inch product line:

Q. And I think my final topic that I’m interested in is, how does Utopban Limited differentiate its metal raised garden beds from competitors such as Vego?

A. I have the eight inches height product, but Vego does not. And then these are the advantages that the manufacturers informed me of in the beginning, which I believe that any advantage that the product carries will be transferred to -- will be translated into my advantages in terms of product sales.

CX-0501 (Li Dep.) at 86:18–87:14.<sup>14</sup>

Respondents contend that “there should be no value to interexchange the usage of tree ring and raised garden bed as a customer can figure this out if he/she needs.” Respondents Post-Hearing Br. at 16. To the extent this argument is understood (there is no value to an 8-inch product development trade secret because the 8-inch tree ring was already known), as explained above, Respondents provided no evidence that an 8-inch raised metal garden bed or tree ring was introduced to the market before Utopban did so, and as alleged by Vego Garden, using its trade secret information.

---

<sup>14</sup> Respondents contend that “[i]f this product [the 8-inch product] indeed afforded a competitive advantage or any obvious competitive advantage, then Mr. Li would certainly have conducted research with respect to the products.” Respondents Post-Hearing Br. at 16. This argument is contradicted by the evidence: Mr. Li testified that he had an 8-inch product, Vego Garden did not, and that Utopban was advantaged by first entry. *Id.*

## PUBLIC VERSION

Respondents also argue that merely contending that something has value does not make it so. Respondents Post-Hearing Resp. Br. at 13. This, however, is not what Vego Garden has done. Instead, Vego Garden adduced evidence, some of it from Respondents themselves, that there was value to being first on the market with a new 8-inch product.

Based on the record evidence, I find that this factor weighs in favor of finding a protectable trade secret.

### **5. Amount of Effort or Money Expended in Development**

Vego Garden contends that it invested significant time and resources in the development of its trade secrets. Complainant Post-Hearing Br. at 26. As to its 8-inch product development trade secret, Vego Garden presented evidence that, during 2021, it expended over \$27,000 in direct research and development costs related to the 8-inch product, Tr. (Xiong) at 29:13–19, and the total costs associated with research and development of this new product line were estimated to be in the \$50,000 range, *id.* at 59:2–9. Additionally, Vego Garden’s witness explained that the research and development into an 8-inch product line, which began in 2021 (“like one year after we launched our initial products”), involved conducting extensive market-side research to gather customer feedback as well as technical discussions with Vego Garden’s manufacturer to ensure the lower-height products would be compatible with Vego Garden’s existing manufacturing equipment, and took around 12 months. Tr. (Xiong) at 57:24–59:9, 134:23–135:6. The Staff agrees that Vego Garden has presented evidence demonstrating its investments in research and development of its 8-inch product development trade secret. Staff Post-Hearing Br. at 21.

Respondents contend that it “is difficult if not impossible to infer or put into context the economic value of product development research” and that the “self-serving assertions made by an interested witness should not be given any weight.” Respondents Post-Hearing Resp. Br. at 14.

## PUBLIC VERSION

Vego Garden's efforts, however, can be put into context; it sought to add a new and less expensive item to its product line, hoping to expand its offerings and increase its market. The evidence, which I find credible, supports Vego Garden's efforts to do so. In addition, while Vego Garden's monetary expenditures were not presented with mathematical certainty, under the circumstances, those estimates were reasonable and reliable.

Respondents also argue that "since Vego shared employees with Worldlink and G&A Partners, it is not clear how many hours these shared employees were devoted to Vego, and in these hours devoted to Vego, how many hours were devoted to research and development." Respondents Post-Hearing Br. at 17. As noted, Respondents' arguments regarding both Worldlink and G&A Partners are unpersuasive. *See, e.g.,* Tr. (Xiong) at 25:12–22, 94:7–19; *see also id.* at 95:5–12; JX-0016 at 2; *see also* JX-0018 at 2. *See* section V.C.2.

Based on the record evidence, I find that this factor weighs in favor of finding a protectable trade secret.

### **6. Extent the Trade Secret Is Readily Ascertainable**

The final *Sausage Casings* factor considers the ease/difficulty with which the asserted trade secret could be properly acquired or duplicated by others. *Sausage Casings*, Inv. Nos. 337-TA-148/169, Initial Determination at 245–246.

Respondents contend that the 8-inch product development trade secret can be easily acquired or duplicated by others, contending that if a customer purchased a raised metal garden bed, they could "cut the height" and make a shorter product. Respondents Post-Hearing Br. at 13; *see also* Respondents Post-Hearing Resp. Br. at 15 (the products can be reverse engineered). I agree with the Staff that Respondents' argument misses the point. Staff Post-Hearing Br. at 21–



## PUBLIC VERSION

22. The correct question is whether the 8-inch product development trade secret was ascertainable before it was used by Respondents to be the first to enter the market.

While in the abstract, selecting a height of a raised metal garden bed product sounds self-evident, the evidence demonstrates that determining the particular appropriate height of a new raised metal garden bed product depended on a number of factors, including a technical assessment of what would be compatible with the manufacturing equipment used to make Vego Garden's products as well as customer feedback to determine what type of product would be appropriate and price effective. Tr. (Xiong) at 57:4–59:9 and 134:23–135:6. Further, and as noted above, there were no manufacturers offering an 8-inch product line when Vego Garden was developing this new product line. *Id.* at 58:10–12 (testifying that there were no competitors in the market offering an 8-inch product line). And tellingly, Utopban's general manager admitted that 8-inch garden bed products were not available on the market before Utopban began selling them. *See* CX-0501 (Li Dep.) at 45:1–9 (stating “for me, I realize that this product was also not available in the market”), 87:9–10 (“I have the eight inches height product, but Vego does not.”). Utopban's recognition that it had an advantage in the market over Vego Garden with an 8-inch product line supports that Vego Garden's 8-inch product development trade secret was not readily ascertainable.

Based on the record evidence, I find that this factor weighs in favor of finding a protectable trade secret.

### **7. Conclusion**

The evidence relating to each of the *Sausage Casings* factors supports that Vego Garden's 8-inch product development trade secret is a protectable trade secret. I accordingly find that Vego Garden's 8-inch product development trade secret is a protectable trade secret.

## PUBLIC VERSION

### **D. The Asserted Protective Film Trade Secret**

Vego Garden's second asserted trade secret relates to the testing and selection of the film it uses to protect the finish of the metal during manufacture and shipping of its raised metal garden bed products. Complainant Post-Hearing Br. at 16 and 27; *see also* Complainant Post-Hearing Resp. Br. at 13.

The Staff contends that Vego Garden's identification of the information it argues comprises this trade secret has changed in that it initially was "research and experimentation relating to the protective film used to protect the finish" of its raised metal garden bed products but that Vego Garden "now appears to argue that this trade secret is the ultimate selection of and/or identity of the protective film itself." Staff Post-Hearing Br. at 22–23. The Staff points to pages 13, 22, and 27 of Vego Garden's post-hearing brief as supporting this change. *Id.* at 23. At page 13, Vego Garden contends that "[w]ithout knowing the film product purchased by Vego for its products, a third party would be required to undergo the same trial and error experimentation undertaken by Vego." At page 22, Vego Garden references "the film Shun Chuen used" and "the film used by Vego." At page 27, Vego Garden states that it "researched and tested various films for over a year to finally determine a product that Vego believed best met the balance between the competing goals of providing protection during manufacturing and shipping and ease of removal."

Based on its arguments, Vego Garden has not changed its articulation of its trade secret, though it has emphasized that its ultimate selection of an appropriate protective film is part of its trade secret, which selection was attained because of its research and testing.

#### **1. Extent the Trade Secret Was Known Outside Vego Garden**

Respondents argue that the protective film was an existing product at the time, and that Vego Garden did not produce evidence showing specific details concerning its alleged research

**PUBLIC VERSION**

and testing of various protective films. Respondents Post-Hearing Br. at 17–18. The Staff argues that the film’s existence and use was likely known to at least the suppliers of such films. Staff Post-Hearing Br. at 24.

The evidence shows that the protective film was known in the industry. For example, Mr. Xiong testified as follows:

- Q. Well, you are aware that protective film is a common feature for metal products, correct?
- A. I know it could be, some people use it, but I’m not sure if it’s in raised garden beds an existing film or it exists.
- Q. Well, Vego was also aware that the protective film that Vego chooses, it already existed at the time, correct?
- A. Yes, it’s an existing product.

Tr. (Xiong) at 139:11–19.

Complainant’s expert, Dr. Beaman, testified as follows:

- Q. It is also your understanding that Vego’s manufacturer purchased the protective film from third-party supplier, correct?
- A. I believe that’s true, yes.
- Q. And a competitor could also purchase the protective film from the third party, correct?
- A. I’m sorry, these headphones are cutting – go ahead. Can you ask that again?
- Q. A competitor could also purchase the protective film from a third-party supplier, correct?
- A. Oh, a competitor, right. Could they? Yeah, it certainly is a film I think you could buy. Yes.

Tr. (Beaman) at 413:20–414:6.

Vego Garden contends that the fact that the film existed “does not automatically indicate that the film would be the most appropriate for Vego’s (or Respondents’) needs.” Complainant

## PUBLIC VERSION

Post-Hearing Resp. Br. at 13. Vego Garden points to testimony of Mr. Xiong, stating that the selection of a protective film for a raised metal garden bed is “a very special and niche occasion,” requiring no damage in the manufacturing process, placement in a box, shipping, and storage in inventory. *Id.*; and Tr. (Xiong) at 61:13–23.

Respondents, however, presented evidence that the process of selecting an appropriate protective film is known and that as such, Vego Garden’s research, development, and selection of its protective film was known outside of Vego Garden. Tr. (Lu) at 366:1–367:25 (protective films are available from various suppliers, which assist in choosing them based on a customer’s need); Tr. (Jones) at 463:7–18 (Respondents’ expert testifying that protective films are commonly used on metal products and that selecting an appropriate film would not be difficult). In addition, Vego Garden has not shown that the circumstances driving the selection of its film are different or unique from those others with similar products face.

While it may have taken time and resources for Vego Garden to determine an appropriate protective film, Respondents’ evidence is persuasive that multiple suppliers provide such films and that such films are common on products similar to raised metal garden beds and the conditions under which such a film must be effective are not unique and would exist with other common products. I find that the evidence supports that Vego Garden’s protective film trade secret was generally known outside Vego Garden.

### **2. Extent the Trade Secret Was Known Inside Vego Garden**

This is addressed in section V.C.2. The evidence supports that Vego Garden has taken appropriate steps to guard its protective film trade secret information within the company.

## PUBLIC VERSION

### 3. Steps Taken by Vego Garden to Protect the Trade Secret

Vego Garden states that it only disclosed its research and testing of various protective films and the ultimate selection of its protective film to its manufacturer, Shun Chuen. Complainant Post-Hearing Br. at 22. The confidentiality obligations between Vego Garden and Shun Chuen are addressed in section V.C.3; *see also* JX-0020. Mr. Xiong testified that Foshan Nahong also knows its selected protective film because it will apply it to product delivered to Shun Chuen. Tr. (Xiong) at 62:2–13. The confidentiality obligations between Shun Chuen and Foshan Nahong are addressed in section VI.B.2.a; *see also* JX-0014C. In addition, Mr. Xiong testified that there was an understanding of confidentiality between Vego Garden and Foshan Nahong. Tr. (Xiong) at 71:3–20.

Respondents contend that because various documents asserted to relate to Vego Garden's protective film are not labeled as confidential, Vego Garden did not take adequate steps to protect its confidential information. Respondents Post-Hearing Br. at 18. CX-0009, CX-0010, and CX-0011 appear to relate to Vego Garden's alleged bending machine trade secret, were initially designated as confidential, but have been de-designated because of the publication of that trade secret. *See* section V.E.1. CX-0023, CX-0025, CX-0026, CX-0027, CX-0028, CX-0029, and CX-0030 are not on the exhibit list. *See* Exhibit List (EDIS Doc. ID 803757).<sup>15</sup> CX-0024 relates to the

---

<sup>15</sup> The private parties had significant difficulties filing correct exhibit lists and submitting correct exhibits. I issued two orders regarding the parties' exhibit list and exhibits, Order No. 28 (Jul. 27, 2023) (EDIS Doc. ID 800959) and Order No. 30 (Aug. 14, 2023) (EDIS Doc. ID 802308), the latter identifying certain errors, directing the parties to file a corrected exhibit list, and advising them to carefully review it before filing. Nonetheless, several more exhibit lists were filed but required correction. The final exhibit list identifying Respondents' exhibits was filed September 6. (EDIS Doc. ID 803915). The final exhibit list identifying Complainant's exhibits, the Staff's exhibits and the joint exhibits was filed on September 5. (EDIS Doc. ID 803757). The listing of Respondents' exhibits in the September 5 filing should be ignored.

## PUBLIC VERSION

mating of a screw and nut and appears irrelevant to the selection of Vego Garden's protective film. CX-0031 relates to vibration testing and appears to be irrelevant to the selection of Vego Garden's protective film. CX-0032 is addressed in section V.C.3.

The evidence supports that Vego Garden took reasonable precautions to protect its protective film trade secret.

#### **4. Value of the Trade Secret to Vego Garden and Competitors**

Vego Garden argues there is substantial value in “keeping the identity of the particular film [Vego Garden] utilized a secret to avoid competitors from free-riding off Vego’s research and development efforts.” Complainant Post-Hearing Br. at 25, *citing* Tr. (Xiong) at 76:20–25 (testifying that knowledge of Vego Garden’s film would save a competitor around one-year of research and development and allow them to launch a product more quickly). Mr. Xiong also testified that selection of a protective film for a raised metal garden bed is “a very special and niche occasion,” requiring no damage in the manufacturing process, placement in a box, shipping, and storage in inventory. Tr. (Xiong) at 61:13–23. Vego Garden’s expert testified that there was “value in the film “in that “you had to get the right kind of polymer, and it takes a little time to get that done.” Tr. (Beaman) at 408:10–17.

Respondents, however, presented evidence that the process of selecting an appropriate protective film is known and that as such, Vego Garden’s research, development, and selection of its protective film has little or no value to competitors. Tr. (Lu) at 366:1–367:25 (protective films are available from various suppliers, which assist in choosing them based on a customer’s need); Tr. (Jones) at 463:7–18 (Respondents’ expert testifying that protective films are commonly used on metal products and that selecting an appropriate film would not be difficult).

## PUBLIC VERSION

While it may have taken time and resources for Vego Garden to determine an appropriate protective film, Respondents' evidence is persuasive that multiple suppliers provide such films and that such films are common on products similar to raised metal garden beds. In addition, Vego Garden has not shown that the circumstances for the selection of its film are different or unique from those that others face. Based on the record evidence, I find that this factor weighs against finding Vego Garden's protective film trade secret protectable as a trade secret.

### **5. Amount of Effort or Money Expended in Development**

Vego Garden presented evidence that, during 2021, it expended over \$27,000 in direct research and development costs related to research and development and selection of its protective film, Tr. (Xiong) at 29:20–22, and it spent approximately 12 months to find a film that best balanced protective attributes and ease of removal by the customer. *Id.* at 61:9–62:1. Additionally, Mr. Xiong testified that the total costs associated with research, development, and selection of its protective film were approximately \$86,000. *Id.* at 30:18–31:1. While Vego Garden's monetary expenditures were not presented with mathematical certainty, under the circumstances, I find that its estimates were reasonable and reliable.

Respondents argue that “since Vego shared employees with Worldlink and G&A Partners, it is not clear how many hours these shared employees were devoted to Vego, and in these hours devoted to Vego, how many hours were devoted to research and development relevant to the alleged protective films.” Respondents Post-Hearing Br. at 18–19. As noted, Respondents' arguments regarding both Worldlink and G&A Partners are unpersuasive. *See* section V.C.2.

Based on the record evidence, I find that this factor weighs in favor of finding a protectable trade secret.

## PUBLIC VERSION

### 6. Extent the Trade Secret Is Readily Ascertainable

Vego Garden argues that, while there are “a number of film manufacturers,” “finding a protective film product that is easily removable by the customer and provides sufficient protection during the manufacturing and shipping process—where the product is often subjected to months of harsh conditions—takes substantial time and effort,” Complainant Post-Hearing Br. at 27, *citing* Tr. (Xiong) at 61:12–62:1. Vego Garden also presented evidence that a chemical analysis of its film may “not necessarily sufficiently reveal the composition of the film,” Tr. (Beaman) at 407:13–24, thus arguing that the identification of its film is not readily ascertainable. Complainant Post-Hearing Br. at 22; *see also* Complainant Post-Hearing Resp. Br. at 14.

Respondents provided evidence that many consumer products have components formed from sheet metal that come with protective films that must be removed by the customer. *See* Respondents Post-Hearing Br. at 18, *citing* Tr. (Jones) at 463:7–14. Respondents also provided evidence that “protective films are generally available from suppliers who have expertise in selecting appropriate films for specific application.” *Id.*, *citing* Tr. (Jones) at 463:15–18. Respondents’ expert, Mr. Jones, testified that the use of protective films in sheet metal construction, which customers are required to remove prior to use, is widespread. Tr. (Jones) at 463:7–14. Mr. Jones further testified that he would not “expect [the process to select appropriate protective film] to be difficult.” Tr. (Jones) at 463:15–18; *see also id.* at 472:5–7 (testifying that a manufacturer can select an appropriate supplier for its protective film). Indeed, Mr. Xiong admitted that the protective film was an existing product. *See* Tr. (Xiong) at 139:16–19. Vego Garden’s expert, Dr. Beaman, also confirmed that Vego Garden’s protective film was available on the open market. *See* Tr. (Beaman) at 413:20–414:6. Respondents have presented persuasive evidence



## PUBLIC VERSION

rebutting Vego Garden's argument that finding a suitable protective film is not readily ascertainable.

Vego Garden has not shown that raised metal garden beds or their shipping conditions are so different from other products that the selection of an appropriate protective film would have particular issues or problems such that such selection would not be readily ascertainable by others.

Based on the record evidence, I find that this factor weighs heavily against finding a protectable trade secret.

### **7. Conclusion**

The evidence demonstrates that Vego Garden took steps to protect its protective film trade secret within Vego Garden (Factor 2), took steps to protect its protective film trade secret outside of Vego Garden (Factor 3), and expended money and effort in developing the trade secret (Factor 5). However, the evidence also supports that the trade secret was known outside Vego Garden (Factor 1), had little to no value (Factor 4), and was readily ascertainable (Factor 6). Considered as a whole, the evidence supports that Vego Garden expended time and money and protected the confidentiality of information that was known to others, namely, how to select a protective film for use in circumstances not dissimilar from other metal products subject to the rigors of manufacture, shipping, and storage. Balancing the evidence relating to the six *Sausage Casings* factors, I find that Vego Garden's protective film trade secret is not a protectable trade secret.

### **E. The Asserted Bending Machine Trade Secret**

Vego Garden's third asserted trade secret relates to improvements in the machinery used to generate the bent corner panels in its raised garden beds, where bending the metal is complicated by the corrugated nature of the metal panels. Complainant Post-Hearing Br. at 13–14 and 16–17.

## PUBLIC VERSION

### 1. Extent the Trade Secret Was Known Outside Vego Garden

Vego Garden acknowledges that the subject matter of its bending machine trade secret became public when it was published in Chinese Patent Application CN 214719610U on November 16, 2021. Complainant Post-Hearing Br. at 14; *see also* JX-0021. Before that publication, Vego Garden contends that its bending machine trade secret was not known outside of Vego Garden. Complainant Post-Hearing Br. at 21.

As recognized by Respondents, Vego Garden has an “affiliate in China named Foshan Baoshuo Intelligent Equipment Manufacturing Co., Ltd. (Baoshuo).” Respondents Post-Hearing Br. at 4; *see also id.* at 6 and 20. Vego Garden states that it shared the details of its bending machine with its affiliate Baoshuo, which manufactured the bending machine that Shun Chuen uses to manufacture Vego Garden’s raised metal garden beds. *See* Tr. (Xiong) at 51:8–10, 205:8–15.<sup>16</sup> Other than Baoshuo, Vego Garden contends that it only disclosed the information in its bending machine trade secret to its manufacturing partner Shun Chuen. Mr. Xiong testified as follows:

- Q. Before the Foshan Baoshuo, FB, patent application was published, was the design of the bending machine known to the public?
- A. It’s not.
- Q. Did Vego tell anyone about the design of the bending machine other than [Foshan Baoshuo] and [Shun Chuen]?
- A. No.

---

<sup>16</sup> Respondents contend that deposition testimony of Mr. Xiong that he “worked with a factory and come up with the final design” is inconsistent with Vego Garden having developed the bending machine trade secret. Respondents Post-Hearing Resp. Br. at 18. Mr. Xiong’s deposition transcript is not in the record and Respondents did not confront him with any supposedly inconsistent testimony at the hearing. In addition, the evidence supports that Vego Garden came up with the bending machine design improvements, which were then implemented by Baoshuo in its machine. Tr. (Xiong) at 66:14–67:6, 67:17–21.

**PUBLIC VERSION**

Tr. (Xiong) at 74:16–22; *see also* SX-0005C.007–008. Mr. Xiong also testified that Foshan Nahong, Shun Chuen’s metal material provider, also had access to its bending machine. Tr. (Xiong) at 67:7–16.

Respondents argue that Vego Garden’s bending machine trade secret was known outside Vego Garden because Green Giant purchased its bending machine from Dongguan Haosheng Automation Equipment Technology Co., Ltd. (Haosheng). *See* Respondents Post-Hearing Br. at 19–20, *citing* JX-0001. Mr. Lu admitted, however, that the roller forming operation in the bending machine Green Giant purchased from Haosheng was different from a standard metal bending machine, stating:

Q. Is it correct that shortly after [Shun Chuen] dumped the Nahong products that you sold them, you ordered a bending machine that was the same as [Shun Chuen]’s bending machine?

A. All the bending machines available in the market are more or less the same. So if you insist on that the bending machine is the same as [Shun Chuen]’s, then it’s – [Shun Chuen] is also getting one of the available machines or equipment on the market.

Because all these bending machines available on the markets are pretty much standard, and, like I said, it is a very well established, an industry already. So most of the machines are the same. And the only difference is the beginning, where the roller, the forming roller is a bit different. That’s the only difference.

Tr. (Lu) at 384:18–385:6.

In addition, Mr. Lu testified that it was only after he told Haosheng what Green Giant needed in a bending machine was Haosheng able to “go back and do it themselves.” CX-0500 (Lu Dep.) at 87:8–15. The evidence thus supports that Green Giant did not order a “standard” bending machine from Haosheng and that Green Giant’s purchase of a bending machine from Haosheng

**PUBLIC VERSION**

does not support that Vego Garden’s bending machine trade secret was known outside of Vego Garden.

Further, supporting that Haosheng’s bending machine was not standard, the evidence shows that Green Giant filed a patent application for its bending machine on November 8, 2021. *See* JX-0009. Contrary to Respondents’ argument that all bending machines are “more or less the same,” the evidence shows that Green Giant’s bending machine was not a standard bending machine. Moreover, Green Giant filed its patent application after it recruited Mr. Yu to advise Green Giant on manufacturing issues. *See* CX-0037 at Nos. 70–74; Tr. (Xiong) at 72:14–73:17, supporting that Green Giant’s machine was based on information it learned from Mr. Yu.

In addition, the evidence shows that unique features of Vego Garden’s bending machine (detailed in JX-0021) are like the features in the bending machine that Green Giant later sought to patent. A representative image from JX-0009, Green Giant’s patent application filed on November 8, 2021, is reproduced below (left), alongside an image from Vego Garden’s patent application, filed on May 27, 2021 (by its affiliate Baoshuo) (JX-0021) (right):

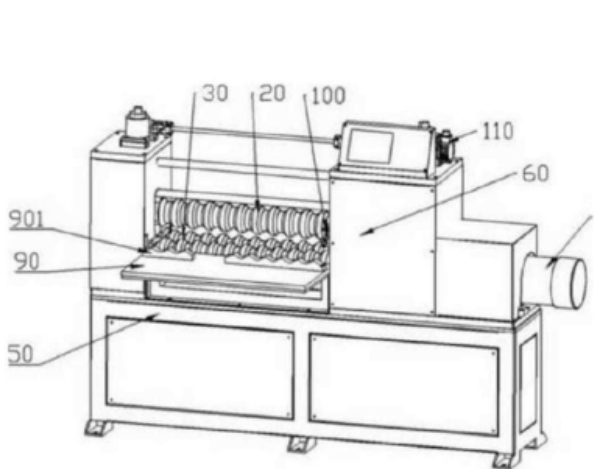

JX-0009 at Fig. 1 (Green Giant)

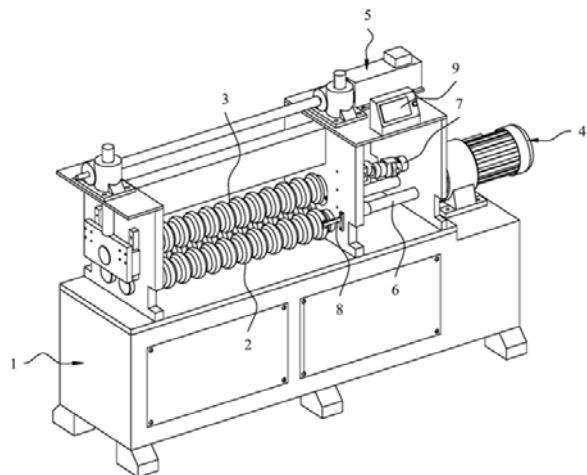

JX-0021 at 5 (Vego Garden/Baoshuo)

## PUBLIC VERSION

Vego Garden's expert, Dr. Beaman, testified that the machine shown in JX-0021 and the machine described in JX-0009 "look like basically the same product. They're very, very similar." Tr. (Beaman) at 406:16–21. Dr. Beaman also reviewed a video of Vego Garden's bending machine and confirmed that there were no significant differences between the machine depicted in JX-0009 and Vego Garden's bending machine. *See id.* (discussing CX-0060). In addition, a comparison of the patent documents reveals that both are directed to improvements in the forming roller configuration and automatically adjusting the roller configuration, exactly what Mr. Lu conceded made Green Giant's machine different from "standard" bending machines and what Vego Garden contends distinguishes its bending machine trade secret from earlier bending machine technology. *See* JX-0021 at [0001] – [0011] and JX-0009 at [0002], [0012], and [0027] (similar patent disclosures). In addition, Vego Garden presented evidence that its roller configuration and automation were benefits of its bending machine trade secret. Complainant Post-Hearing Br. at 13–14.

Respondents assert that "[c]ontrary to Complainant's allegation of 'new machine,' Complainant's expert witness also testified the existence [sic] of 'some prior-art out there about metal-bending machines' which further supports the notion that the metal bending machine is not something innovative." Respondents Post-Hearing Br. at 18, *citing* Tr. (Beaman) at 412:18–21. The testimony from Vego Garden's expert, however, is opposite to what Respondents represent. In the portion of testimony cited by Respondents, Vego Garden's expert makes the point that the prior art bending machines had to manually adjust. Automatic adjustment is identified by Vego Garden as part of its bending machine trade secret. Complainant Post-Hearing Br. at 14.

The evidence supports that Vego Garden's bending machine trade secret was not known outside of Vego Garden before the publication of its patent application in November 2021.

## PUBLIC VERSION

### 2. Extent the Trade Secret Was Known Inside Vego Garden

This is addressed in section V.C.2. The evidence supports that Vego Garden has taken appropriate steps to guard its bending machine trade secret information within the company.

### 3. Steps Taken by Vego Garden to Protect the Trade Secret

Vego Garden states that it only disclosed its bending machine trade secret to Shun Chuen and Baoshuo. Tr. (Xiong) at 74:16–22. The confidentiality obligations between Vego Garden and Shun Chuen are addressed in section V.C.3; *see also* JX-0020. Vego Garden states that Foshan Nahong also had access to its bending machine. Tr. (Xiong) at 67:7–16. The confidentiality obligations between Shun Chuen and Foshan Nahong are addressed in section VI.B.2.a; *see also* JX-0014C. In addition, Mr. Xiong testified that there was an understanding of confidentiality between Vego Garden and Foshan Nahong. Tr. (Xiong) at 71:3–20.

Respondents contend that Vego Garden “did not produce evidence or testimony regarding Baoshuo’s internal procedure in protecting the alleged trade secrets.” Respondents Post-Hearing Br. at 20. Respondents recognize, however, that Baoshuo is an affiliate company of Vego Garden. Respondents Post-Hearing Br. at 4, 6, and 20. That type of relationship supports a confidentiality obligation between Vego Garden and Baoshuo. *Expeditors Int’l of Washington, Inc. v. Direct Line Cargo Mgmt. Servs., Inc.*, 995 F. Supp. 468, 481–82 (D.N.J. 1998); *see also* Restatement (Third) of Unfair Competition § 41.

In addition, the evidence shows that Vego Garden authorized Baoshuo to seek patent protection for its bending machine, Tr. (Xiong) at 67:17–21, and Baoshuo is in fact listed as the patentee. JX-0021 at 1. Given its interest in the patent, Baoshuo would have an interest in maintaining the confidentiality of the bending machine design until publication of the patent document. *See Timely Products Corp. v. Arron*, 523 F.2d 288, 302–03 (2d Cir. 1975) (“Arron’s

## PUBLIC VERSION

relationship to Costanzo was one of mutual trust and confidence which imposed upon him the implied obligation not to subvert that policy.”).

Further, the size and sophistication of the parties supports a confidential relationship between Vego Garden and Baoshuo. Tr. (Xiong) 200:19–201:4 (Vego Garden is a small start-up company); and 51:8–13 (Baoshuo makes the bending machine for Vego Garden’s manufacturer). *See Learning Curve Toys*, 342 F.3d at 726 (“[A]s part of the reasonableness inquiry, the jury could have considered the size and sophistication of the parties, as well as the relevant industry.”).

Respondents also contend that because various documents asserted to relate to Vego Garden’s machine trade secret are not labeled as confidential, Vego Garden did not take adequate steps to protect its confidential information. Respondents Post-Hearing Br. at 20. These issues are addressed in sections V.C.3 and V.E.1.

The evidence supports that Vego Garden took reasonable precautions to protect its bending machine trade secret.

#### **4. Value of the Trade Secret to Vego Garden and Competitors**

In discussing the value of its bending machine trade secret, Vego Garden argues that “Mr. Xiong’s new bending machine design significantly increased output, consistency, and quality.” Complainant Post-Hearing Br. at 25, *citing* Tr. (Xiong) at 63:9–64:1. The Staff agrees that Vego Garden’s bending machine trade secret derived value by providing manufacturing efficiencies that were not generally known throughout the wider industry. Staff Post-Hearing Br. at 29–30.

The evidence shows that Vego Garden’s bending machine design improvements afforded a competitive advantage to Vego Garden. Tr. (Xiong) at 62:14–64:1, 66:14–67:6; and Tr. (Beaman) at 408:3–9. As Mr. Xiong testified:

Q. Is the new machine faster or slower than the old system in terms of output?

## PUBLIC VERSION

- A. It is a lot faster.
- Q. And is the new machine better or worse than the previous machines in terms of consistency and quality of the product that comes out?
- A. Yeah. It has a lot of improvement because we consolidated the three machines into one machine. So you see the time from – in old way, three machines, you have to take off the panels, take it out to put into a second machine and take it out and put into a third machine in order to bend it. In the new machine you basically put the panels into just one machine and it's going to bend into the final sheet. So this will save the time where you put it into different machine. It avoids scratches and damage and it also has a much better precision and a much higher capacity. You save the people, the labor, and also the time to switch from different machines.

Tr. (Xiong) at 63:9–64:1. Dr. Beaman confirmed Mr. Xiong's testimony. *See* Tr. (Beaman) at 408:3–9 (“[T]here's value certainly in the machine that is now capable of much quicker construction or manufacture of curved tiles.”); *see also id.* at 415:20–416:3. The evidence further shows that Vego Garden's bending machinery provides significant economic value by consolidating three machines into one while increasing quality and consistency. Tr. (Xiong) at 66:14–67:6. In particular, Vego Garden's bending machine allows Vego Garden to produce the curved panels in less time, while reducing the amount of labor required. *Id.* at 63:15–64:1.

Respondents argue that Vego Garden's bending machine technology is generally known in the industry, and therefore “has no economic value.” Respondents Post-Hearing Resp. Br. at 19. As discussed above and in section V.E.1, the evidence supports that Vego Garden's bending machine technology was not known before the publication of its patent application.

Based on the record evidence, I find that this factor weighs in favor of a protectable trade secret.

### **5. Amount of Effort or Money Expended in Development**

Vego Garden presented evidence that, during 2021, it expended over \$54,000 in direct research and development costs related to its bending machine, Tr. (Xiong) at 29:23–25, and that



## PUBLIC VERSION

it took approximately a year to design its machine. Tr. (Xiong) at 66:14–67:6. Additionally, Vego Garden’s witness explained that the total costs associated with research and development of its bending machine were likely around \$300,000. *Id.* at 30:18–31:4. Vego Garden has thus presented evidence demonstrating its investments in research and development of its bending machine trade secret, which Respondents failed to rebut.

Respondents argue that “since Vego shared employees with Worldlink and G&A Partners, it is not clear how many hours these shared employees were devoted to Vego, and in these hours devoted to Vego, how many hours were devoted to research and development relevant to the alleged metal-forming machine.” Respondents Post-Hearing Br. at 20–21. As noted, Respondents’ arguments regarding both Worldlink and G&A Partners are unpersuasive. *See, e.g.*, Tr. (Xiong) at 25:12–22, 94:7–19; *see also id.* at 95:5–12; JX-0016 at 2; *see also* JX-0018 at 2. *See* section V.C.2.

Based on the record evidence, I find that this factor weighs in favor of finding a protectable trade secret.

### **6. Extent the Trade Secret Is Readily Ascertainable**

Respondents contend that the evidence shows that the bending machine trade secret can be easily duplicated by others. *See* Respondents Post-Hearing Br. at 19–20. In particular, Respondents allege that Green Giant’s ability to purchase its own bending machine from Haosheng demonstrates that bending machines are generally known in the industry. *See id.*

Mr. Lu’s testimony that the bending machine that Green Giant ordered from Haosheng had a specific roller configuration and could not be provided by Haosheng without information from him supports that the bending machine Green Giant needed to manufacture raised metal garden bed products that would compete with Vego Garden’s products was not readily ascertainable. Tr. (Lu) at 384:18–385:6; and CX-0500 (Lu Dep.) at 87:8–15. In addition, Green Giant’s patent

## PUBLIC VERSION

application cuts against its argument that the Vego Garden bending machine trade secret was generally known or readily ascertainable in the industry. As noted, Green Giant's patent application is directed to a machine that is "very, very similar" to that described in the patent application that Vego Garden filed in cooperation with Baoshuo. Tr. (Beaman) at 406:16–21; *compare* JX-0009 with JX-0021. Indeed, in filing its patent application, Green Giant is effectively conceding that the technology behind the bending machine is innovative and not generally known in the industry. In addition, the similarity in the patent disclosures and the timing of Green Giant's patent application, after it had recruited Mr. Yu to assist with manufacturing issues, supports that Green Giant obtained the information in its patent application from Vego Garden.

Vego Garden also presented persuasive evidence that its bending machine was unique in the industry and consolidated processes that previously would require three machines. Tr. (Xiong) at 62:14–63:8. Dr. Beaman testified that Vego Garden's bending machine reduced capital costs, and contrasted Vego Garden's machine with prior art metal-bending machines requiring manual readjustment. *See* Tr. (Beaman) at 412:18–413:2. Further, and as noted above, Vego Garden, through its affiliate Baoshuo, sought patent protection for its new machine. Tr. (Xiong) at 67:17–21; JX-0021.

The record evidence thus supports that Vego Garden's bending machine trade secret was not readily ascertainable. Based on the record evidence, I find that this factor weighs in favor of finding a protectable trade secret.

### 7. Conclusion

The evidence relating to each of the *Sausage Casings* factors supports that Vego Garden's bending machine trade secret is a protectable trade secret. I accordingly find that Vego Garden's bending machine trade secret is a protectable trade secret.

## PUBLIC VERSION

### VI. MISAPPROPRIATION OF THE ASSERTED TRADE SECRETS

Having found protectable trade secrets, I next consider whether there has been misappropriation of them. *Crawler Cranes*, Inv. No. 337-TA-887, Comm’n Op. at 34. This involves consideration of ownership, confidential disclosure or wrongful acquisition, and use. *Rubber Resins*, Inv. No. 337-TA-849, Comm’n Op. at 10, *citing Sausage Casings*, Inv. Nos. 337-TA-148/169, Initial Determination.

#### A. Ownership

“[O]ne ‘owns’ a trade secret when one knows of it, as long as it remains a secret.” *Crawler Cranes*, Inv. No. 337-TA-887, Initial Determination at 134, n.41. A trade secret may be transferred; however, “its continuing secrecy provides the value, and any general disclosure destroys the value.” *Id.*, *citing DTM Research, LLC v. AT&T Corp.*, 245 F.3d 327, 331 (4th Cir. 2001).

Vego Garden asserts that it owns each of the asserted trade secrets because it developed them and has consistently used them. Complainant Post-Hearing Br. at 10–15 and 21. While Respondents dispute that Vego Garden “identif[ied] the alleged trade secrets with sufficient particularity,” they do not appear to dispute that Vego Garden owns or possesses a proprietary interest in the asserted trade secrets. Respondents Post-Hearing Resp. Br. at 20; *see also* Staff Post-Hearing Resp. Br. at 9.<sup>17</sup> In addition, the evidence supports that Vego Garden developed, used, and is using its asserted trade secrets. Tr. (Xiong) at 57:24–58:9 (8-inch product development trade secret); Tr. (Xiong) at 60:3–61:11 (protective film trade secret); and Tr. (Xiong) at 62:14–63:8 (bending machine trade secret).

---

<sup>17</sup> As explained in section V.A, Vego Garden has sufficiently identified its trade secrets.

## PUBLIC VERSION

I therefore find that, to the extent that protectable trade secrets are found to exist, the evidence supports that Vego Garden owns the asserted trade secrets.

### **B. Wrongful Disclosure or Acquisition**

Misappropriation requires evidence that the “complainant disclosed the trade secret to respondent while in a confidential relationship or that the respondent wrongfully took the trade secret by unfair means.” *Rubber Resins*, Inv. No. 337-TA-849, Comm’n Op. at 10. A taking is wrongful if, for instance, the respondent used a trade secret acquired by an employee under circumstances giving rise to a secrecy obligation. *See id.* at 41–42, affirming reasoning in the initial determination that Respondent “wrongfully took Complainant’s trade secrets by unfair means” through copying information obtained by the complainant’s former employees under confidentiality agreements, *Rubber Resins*, Inv. No. 337-TA-849, Initial Determination at 406.

Vego Garden contends that its trade secret information was inappropriately acquired by Mr. Lu, who at the relevant time worked for Foshan Nahong, a supplier of Vego Garden’s manufacturer Shun Chuen and is now the CEO of Green Giant, from Mr. Yu, an engineer at Shun Chuen, the manufacturer of Vego Garden’s raised metal garden beds. Complainant Post-Hearing Br. at 28; *see also* Staff Post-Hearing Br. at 36.

As an initial matter, Respondents contend that Vego Garden “attempted to add new theory of Respondent Green Giant’s CEO, Mr. Lu’s prior involvement at Foshang [sic, Foshan] Nahong” to its misappropriation allegation but that Vego Garden “never disclosed such new theory in its pre-hearing brief.” Respondents’ Post-Hearing Br. at 3; *see also id.* at 20. This argument is baseless. In its pre-hearing brief, Vego Garden specifically identified the central role of Mr. Lu and Foshan Nahong to its trade secret misappropriation allegations. Complainant Pre-Hearing Br. at 19–21; *see also* Staff Post-Hearing Resp. Br. at 9, n.5. Respondents’ attempt to distance Mr. Lu

## PUBLIC VERSION

from Foshan Nahong is meritless. In its Counterclaim, Green Giant states that Mr. Lu worked at Foshan Nahong. Counterclaim, ¶ 7.

Before addressing whether trade secret information was wrongfully disclosed or acquired, I address several issues raised by Respondents regarding whether information from Shun Chuen was properly considered.

### 1. Materials from Shun Chuen Were Properly Considered

In arguing that its trade secrets were misappropriated, Vego Garden relies on information obtained from its manufacturing partner, Shun Chuen. Complainant Post-Hearing Br. at 28–32 (relying on, *inter alia*, JX-0014C, JX-0015C). Respondents characterize documents from Shun Chuen as “unequivocally problematic,” contend that they should not be considered, and assert that Vego Garden should be sanctioned for their use at the hearing. Respondents Post-Hearing Resp. Br. at 23–25.

I agree with the Staff that “Respondents waived any arguments or objections concerning the authenticity and reliability” of JX-0014C and JX-0015C “because Respondents failed to timely object to such documents prior to or during the evidentiary hearing and/or failed to fully address such issues” in their initial post-hearing brief. Staff Post-Hearing Resp. Br. at 9–10. Respondents did not object to the introduction into evidence of JX-0014C or JX-0015C at the evidentiary hearing and in fact relied on those documents themselves. Tr. (Xiong) at 71:21–72:7 (Vego Garden introducing JX-0014C without objection), 154:19–156:13 (Respondents questioning Mr. Xiong about JX-0014C), and 157:6–158:4 (Respondents introducing JX-0015C). Indeed, Respondents adduced the following testimony from Mr. Xiong regarding JX-0014C, which is a July 2019 Confidentiality Agreement between Shun Chuen and Foshan Nahong:

Q. So is this a true and correct copy of the agreement that it alleges to be?

**PUBLIC VERSION**

A. It is true document.

Q. How do you know?

A. Because I asked Shunchuen to produce for me and they did their work, and I trust them they're going to do their -- they don't have to falsify anything, to make anything fake of anything.

Tr. (Xiong) at 156:6–13; *see also* Tr. (Xiong) at 157:6–157:8 (as to JX-0015C). Moreover, since JX-0014C and JX-0015C are *joint* exhibits, Respondents are not in a position to now object to their introduction into evidence.<sup>18</sup>

Respondents also waived any argument that no documents from Shun Chuen, including JX-0014C and JX-0015C, should have been admitted into evidence because they did not make that argument in their initial post-hearing brief. *See* Order No. 14 (Ground Rules) at Ground Rule 14.1 (“Any issue for which a party has the burden of proof that is not addressed in detail in the initial post-hearing initial brief shall be deemed abandoned or withdrawn.”) Respondents did not argue that Shun Chuen documents, including JX-0014C and JX-0015C should not have been admitted into evidence.<sup>19</sup> *See* Respondents Post-Hearing Br. at 22.

In arguing that Shun Chuen documents should not be considered, Respondents contend that “[w]ithout a person who has direct knowledge from [Shun Chuen] to testify, Respondents had no opportunity to cross-examine anyone with direct knowledge of the [Shun Chuen] documents, or who prepared the purported confidentiality agreement that was purportedly signed by Mr. Lu.”

---

<sup>18</sup> To the extent Respondents now object to CX-0014, a Shun Chuen Employee Handbook, such objection was waived because it was not raised at the evidentiary hearing. Tr. (Xiong) at 72:8–13 (introducing CX-0014 without objection). The same is true for CX-0007C, identified as an Order Contract, and CX-0008C, identified as a Contract. Any objections to these documents were waived because they were not raised at the evidentiary hearing. Tr. (Xiong) at 79:1–81:8 (CX-0007C) and 68:13–22 (CX-0008C).

<sup>19</sup> *See also* Order No. 25 (May 19, 2023) at 15–17 (EDIS Doc. ID 797935) (denying Respondents’ motion in limine regarding JX-0014C and JX-0015C).

## PUBLIC VERSION

Respondents Post-Hearing Resp. Br. at 24. Mr. Lu, however, testified about JX-0014 and JX-0015 and Respondents had the opportunity to and did elicit testimony from him. *See* Tr. (Lu) at 369:17–372:21.

In addition, the failure to have a witness from Shun Chuen testify at the evidentiary hearing lies squarely with Respondents. Respondents have known from when the Complaint in this investigation was filed that Shun Chuen was involved in Vego Garden’s allegations. Indeed, Mr. Yu of Shun Chuen was a central figure in Vego Garden’s allegations. As noted in Order No. 16, Respondents knew about Mr. Yu and his potential relevance to this investigation since at least as early as November 3, 2022, when it had access to Confidential Exhibit 1 to the Amended Complaint, which identifies Mr. Yu. EDIS Doc. ID 779976 at Conf. Ex. 1. Mr. Yu was also identified in Vego Garden’s December 5 Preliminary Disclosure of Trade Secret and Copyright claims. EDIS Doc. ID 793340 at Conf. Ex. 6, pp. 2, 3, and 5.

Not only did Vego Garden identify Mr. Yu of Shun Chuen, but Green Giant did, too. Mr. Li, Green Giant’s corporate deposition designee, testified that he first spoke to Mr. Yu in October or November 2022, EDIS Doc. ID 793216 at Ex. C, p. 15; Green Giant identified Mr. Yu in its December 12 interrogatory responses, EDIS Doc. ID 793340 at Ex. 7, pp. 11–12; and Green Giant identified Mr. Yu in its December 2022 counterclaim, EDIS Doc. ID 786929, ¶¶ 12, 13, 15, 16, 26, 33, and 37.

Despite the early and repeated identifications of Mr. Yu, Respondents belatedly attempted to add him to their witness list. *See* Order No. 16 (Apr. 3, 2023) (EDIS Doc. ID 794316) (denying Respondents’ motion to amend their witness list to identify Mr. Yu as belatedly filed after the close of fact discovery and as prejudicial to both Vego Garden and the Staff).

## PUBLIC VERSION

The failure to have a witness from Shun Chuen testify at the evidentiary hearing lies with Respondents and does not provide a basis to exclude any Shun Chuen documents.

### **2. The Confidentiality Obligations of Mr. Lu and Mr. Yu**

Vego Garden contends that Mr. Lu, who worked for Foshan Nahong, and Mr. Yu, who worked for Shun Chuen, were subject to confidentiality obligations, which precluded them from disclosing and using Vego Garden's trade secret information. Complainant Post-Hearing Br. at 7–8. The Staff agrees. Staff Post-Hearing Br. at 36–37.

As an initial matter, Respondents purport to identify entities that *do not* have confidential relationships to suggest that there was no disclosure of information subject to a confidentiality obligation. Respondents Post-Hearing Br. at 21–22. Specifically, Respondents contend that there is no confidential relationship between Vego Garden and Green Giant or Utopban. *Id.* at 21.<sup>20</sup> Respondents also contend that Green Giant (and as the general manager of Green Giant, Mr. Lu) never entered into confidential relationships with: (1) Vego Garden's manufacturer, Shun Chuen; (2) Mr. Yu; and (3) Foshan Nahong. *Id.* I agree with the Staff that while these assertions may be true, they are not relevant. Staff Post-Hearing Br. at 35. The issue instead, is whether Mr. Lu, as an employee of Foshan Nahong, and Mr. Yu, as an employee of Shun Chuen, were subject to confidentiality obligations precluding their disclosure or acquisition of Vego Garden's trade secret information.

For the reasons detailed below, the evidence demonstrates that confidentiality obligations precluded the disclosure and acquisition of Vego Garden's trade secret information.

---

<sup>20</sup> Respondents contend that: (1) “there is no confidential relationship between Complainant and Respondents;” (2) “Green Giant never entered into confidentiality relationship [sic] with Vego;” and (3) there are “no confidentiality obligations or relationships that existed between Vego and Respondents.”



**PUBLIC VERSION**

**a) The Confidentiality Agreements Between Shun Chuen and Foshan Nahong Imposed Confidentiality Obligations on Mr. Lu and Were Not Forged**

As an employee of Foshan Nahong, Vego Garden contends that Mr. Lu was subject to confidentiality agreements between Shun Chuen and Foshan Nahong. Complainant Post-Hearing Br. at 8, *citing* JX-0014C and JX-0015C. According to the terms of a Confidentiality Agreement between Shun Chuen and Foshan Nahong, dated July 2019, (JX-0014C), “all business or other related requests by [Shun Chuen] or [Foshan Nahong] . . . shall constitute and continue to become confidential material, . . . .” JX-0014C. This document further states that “[w]ithout the written consent of the authorized representative of [Shun Chuen], such confidential data shall not be copied, and the information contained in such confidential data shall not be disclosed to any individual, enterprise, or company other than the parties under the Agreement.” *Id.*, ¶ 6. According to the terms of a Purchase Contract between Shun Chuen and Foshan Nahong, dated July 2019, (JX-0015C), [REDACTED]

[REDACTED]

[REDACTED]

[REDACTED]

[REDACTED]

[REDACTED] JX-0015C at 8.

Respondents do not dispute the content of the confidentiality agreements, JX-0014C and JX-0015C, but contend that Mr. Lu’s signatures were forged. Respondents Post-Hearing Br. at 22; and Respondents Post-Hearing Resp. at 4, n.2 and 20–21, n.8. The Staff asserts that Respondents have not demonstrated that JX-0014C or JX-0015C were forged. Staff Post-Hearing Br. at 35.

Under Ground Rule 12.3.1, “All documents that appear to be regular on their face shall be deemed authentic unless it is shown by particularized evidence that a document is a forgery or is

**PUBLIC VERSION**

not what it purports to be.” Order No. 14 (Ground Rules). For the reasons explained below, I find that Respondents have not provided such evidence.

Mr. Lu testified that the signatures on JX-0014C and JX-0015C are not his. Respondents Post-Hearing Br. at 22, *citing* Tr. (Lu) at 370:16–23 and 371:4–23. The record evidence, however, demonstrates that Mr. Lu is not credible.

For example, when asked by his counsel whether he was “familiar with the company called Foshan Nahong,” Mr. Lu replied that he “collaborated with this company before on a few projects.” When asked to “tell us a little bit more about your relationship with Foshan Nahong,” Mr. Lu testified that “we simply had some business deals together. That’s it.” Tr. (Lu) at 335:3–13. Given that Mr. Lu worked for Foshan Nahong and is at the center of Vego Garden’s allegations, his attempt to minimize his involvement with Foshan Nahong demonstrates that he is not credible.

As another example, the evidence demonstrates that Mr. Xiong and Mr. Lu engaged in an extensive text chat when Mr. Lu was employed by Foshan Nahong and even after he started Green Giant as a competitor to Vego Garden. JX-0004. At the hearing, Mr. Lu conceded that despite continuing communications with Mr. Xiong, he never told him that he was the owner of Green Giant:

Q. And in your chat, even as late as November ‘21, when Robert [Xiong] had discovered from Mr. [Xie] that Green Giant was selling raised garden beds identical to Vego’s, and when you were supplying Green Giant, you never confessed you were the owner of Green Giant, right?

A. Correct.

Tr. (Lu) at 388:19–23. Confirming Mr. Lu’s deception, at the end of their text chat, Mr. Xiong stated: “How stupid of me to trust you blindly.” JX-0004 at 36. Mr. Xiong testified that he did not

## PUBLIC VERSION

learn that Mr. Lu was the founder and general manager of Green Giant until after this investigation was instituted. Tr. (Xiong) at 203:8–205:2.

In attempting to explain his failure to tell Mr. Xiong that he had founded a competitor company, Mr. Lu testified that because his exchanges with Mr. Xiong were “about the technological processes and the know-hows” and “not really concerning business side of things” and because Mr. Xiong and Shun Chuen have a relationship, “it would be unethical for me to bring up anything in terms of business. Tr. (Lu) at 389:5–10. Right after Mr. Lu testified that it would be unethical of him to tell Mr. Xiong that he had started a competitor company, instead leaving Mr. Xiong to understand that the relationships between Vego Garden, Shun Chuen, and Foshan Nahong remained unchanged, Mr. Lu testified that Mr. Xiong was unethical because Mr. Xiong gave Mr. Lu advance notice of Vego Garden’s intent to change materials for its raised metal garden beds. Tr. (Lu) at 389:11–390:11.

Given that Mr. Lu was equivocal at the hearing about his relationship with Foshan Nahong, withheld essential information from Mr. Xiong (that he had founded a competitor company), testified that it would have been unethical for him to be honest with Mr. Xiong, and then, without apparent basis, charged Mr. Xiong with being unethical, I find that Mr. Lu has shown himself to be untrustworthy and to lack credibility. I therefore do not credit Mr. Lu’s testimony that his signatures were forged on JX-0014 and JX-0015.

Respondents also rely on the opinion of their handwriting expert, Mr. Bart Baggett, in asserting that Mr. Lu’s signatures on JX-0014C and JX-0015C were forged. Respondents Post-Hearing Br. at 22, *citing* Tr. (Baggett) at 252:15–25. Mr. Baggett compared what were represented as five known signatures of Mr. Lu with the signatures identified as Mr. Lu’s in JX-0014C and JX-0015C. When he did so, the information surrounding the known signatures was redacted, so

## PUBLIC VERSION

that Mr. Baggett did not know the context of the known signatures when offering his opinion. *See* Vego Garden Motion in Limine No. 4 at Ex. 1 (EDIS Doc. ID 795737). While Respondents contended that content of the redactions was personal and had “no relevance or bearings to the merits of the case,” EDIS Doc. ID 796138 at 5, I ordered the production of that information if they intended to rely on Mr. Lu’s five known signatures. Order No. 25 at 5–6. Respondents did so. *See* RX-0090C.

With this background, Mr. Baggett testified at the hearing as follows:

- Q. And you compared the known signatures with the questioned -- purported signatures on the questioned document, correct?
- A. I did, yes, sir.
- Q. So what is your opinion when you did a comparison between the known signatures and the question -- the purported signatures on the questioned document?
- A. The person who wrote the known signatures is not the author of the person who signed Mr. Lu’s name on those five questioned documents or that one questioned document with his signature.

Tr. (Baggett) at 252:15–25.

Complainant’s expert, Dr. Linton Mohammed, testified that to “exclude a writer if there are dissimilarities between questioned and known signatures you have to account for almost everything that can account for those dissimilarities,” including “age, illness, health, drugs, medication, writing conditions, writing instruments, were they sitting, were they standing, alcohol is another feature.” Tr. (Mohammed) at 275:9–17. Dr. Mohammed testified that a person’s signature can also vary depending on the type of document being signed. For example, a person’s signature may be quite different when signing for a FedEx package than when signing a last will and testament a few hours later in an attorney’s office. *Id.* at 276:24–277:10. To account for these issues, Dr. Linton testified that a minimum of twenty known signatures is necessary, and that

## PUBLIC VERSION

number can be as high as 300. Dr. Mohammed testified that five known signatures is not enough to exclude a questioned signature. *Id.* at 275:19–22, 276:12–23, and 278:3–8. Dr. Mohammed also testified that he did not perform a signature analysis because the five known exemplars were not sufficient. *Id.* at 283:4–10.

Based on the record evidence, I find that Mr. Baggett’s methodology was not reliable. I therefore give his opinion no weight. While Mr. Baggett testified regarding his comparison of the five known samples and the signatures on JX-0014C and JX-0015C, Tr. (Baggett) at 244:21–257:5 and 257:14–260:11, he did not provide any explanation of what may have accounted for dissimilarities in the condition of the writer or the circumstances of the signature, as Dr. Mohammed credibly testified was necessary, thus rendering his opinion unreliable. And while Mr. Baggett mentioned 27 known exemplars of Mr. Lu’s signature, Tr. (Baggett) at 251:17–18, the additional 22 (from the five in his expert report) are not in the record. *See* RX-0090C. Mr. Baggett’s use of five known exemplars as a comparison to the signatures in JX-0014C and JX-0015C was insufficient for him to render a reliable opinion.

In their post-hearing responsive brief, Respondents ask: “If Mr. Lu did sign any confidentiality agreement or if any of these signatures are truly signed by Mr. Lu, why bother to find a handwriting expert to do the examination of these signatures?” Respondents Post-Hearing Resp. Br. at 22. The correct question, however, is whether Respondents have presented particularized, credible, or reliable evidence that JX-0014C and JX-0015C are forgeries or are not what they purport to be. *See* Ground Rule 12.3.1. They have not. I find that Mr. Lu signed both JX-0014C and JX-0015C and was subject to the confidentiality obligations between Foshan Nahong and Shun Chuen.

**PUBLIC VERSION**

**b) The Shun Chuen Employee Handbook Imposed Confidentiality Obligations on Mr. Yu**

The evidence shows that as an employee of Shun Chuen, Mr. Yu was subject to the confidentiality provisions of the Shun Chuen employee handbook, which states:

Article 48 All employees of the company have an obligation to keep the company's business secrets. Employees must meticulously keep confidential the documents in their possession and shall comply with the company's confidentiality policy. No employee may disclose any payroll and other technical information of the company or ask about it (including design drawings, production processes, customer information, and information about contracts). No photography shall be allowed without the consent of the company.

Article 49 No employee of the company shall be allowed to read any documents, letters, accounting books, or financial statements beyond their authorization, or disclose any documents under their management to others. He/she may not disclose any equivalent confidential information of the company to the outside. Any letters and mail sent in the name of the company must be approved by the relevant management. No employee shall ask for, print, or copy any materials of the other departments without the approval of the department manager or the authorization of the General Manager.

CX-0014 (Shun Chuen Employee Handbook) at Articles 48–49.

Respondents argue that there is no evidence showing that earlier versions of CX-0014 (which indicates on its face that it is the ninth version) contained similar confidentiality provisions. Respondents Post-Hearing Br. at 22–23. As noted by the Staff, however, the revision dates identified in CX-0014 show that Articles 48 and 49 were not revised for the time between when Vego Garden began working with Shun Chuen and the present. CX-0014 (revisions in December 2020, March 2021, and July 2021); and Tr. (Xiong) at 202:25–203:5 (Vego Garden began working with Shun Chuen in the later part of 2020). Respondents suggest that Articles 48 and 49 could have been different before December 2020. Respondents Post-Hearing Br. at 22–23; and Respondents Post-Hearing Resp. Br. at 24. Whether that is so is irrelevant, however, because the

## PUBLIC VERSION

evidence supports that Mr. Yu was employed by Shun Chuen after the employee handbook with Articles 48 and 49 as recited in CX-0004 was issued, and thus would have been subject to them. *See* CX-0015 (employee sign-in); *see also* Tr. (Xiong) at 49:9–12 (testifying that Mr. Yu was Vego Garden’s point of contact at Shun Chuen).

Accordingly, the evidence demonstrates that Mr. Yu had confidentiality obligations as an employee of Shun Chuen.

### **c) Respondents’ Evidence and Arguments That There Were No Confidentiality Obligations Are Not Persuasive**

In attempting to refute Mr. Yu’s confidentiality obligations to Shun Chuen, Respondents rely on testimony of Mr. Lu that he was “sure that there is no confidentiality agreement signed or obligation between Mr. Yu and ShunChuen because ShunChuen was not generous with pay and that ShunChuen refused to have the employee sign confidentiality clause because it would cost them extra to do so.” Respondents Post-Hearing Br. at 23, *citing* Tr. (Lu) 371:24–25 and 372:1–18. In testimony not cited by Respondents, Mr. Lu testified that “last year after I found out about this lawsuit, I asked Yu Xiong again, and he told me that there was nothing confidential or confidentiality obligation between him and Shunchuan.” Tr. (Lu) at 372:18–21. Mr. Lu’s testimony is, by his own admission, motivated by this litigation, in which he has been a non-credible witness. In addition, Mr. Lu’s testimony that Shun Chuen was uninterested in confidentiality is specifically refuted by the written confidentiality agreement between Shun Chuen and Foshan Nahong, JX-0014C, the purchase contract between Shun Chuen and Foshan Nahong, JX-0015C, and the Shun Chuen employee handbook, CX-0014. I find Mr. Lu’s testimony regarding Mr. Yu’s confidentiality obligations unreliable.

## PUBLIC VERSION

Respondents also point to what they characterize as Mr. Yu's employment agreement with Shun Chuen with the confidentiality and non-compete clauses deleted. Respondents Post-Hearing Br. at 23, *citing* RX-0029C and Tr. (Lu) 372:22–373:4. While Respondents cite to RX-0029C, that document should have been identified by Respondents' counsel as RDX-0029C because it was entered for "identification purposes only." Tr. (Lu) at 373:5–6. Respondents do not point to a particular provision of this agreement that extinguishes a confidentiality obligation on Mr. Yu. Nor, more importantly, do they explain how this document abolishes the confidentiality obligations imposed on Mr. Yu by the Shun Chuen employee handbook.

I find that Respondents' attempts to refute Mr. Yu's confidentiality obligations are unpersuasive and that Mr. Yu had confidentiality obligations based on the Shun Chuen employee handbook as well as based on the confidentiality agreement between Vego Garden and Shun Chuen, JX-0020, and the earlier oral confidentiality agreement between Vego Garden and Shun Chuen. *See* section V.C.3.

### **3. Wrongful Disclosure or Acquisition by Mr. Lu**

Mr. Lu worked for Foshan Nahong, a material supplier to Shun Chuen (Vego Garden's manufacturer). Tr. (Lu) 335:6–22. Mr. Lu testified that a delivery of metal coil for raised metal garden beds was rejected by Vego Garden and Shun Chuen in April 2021, costing him substantial commissions. Tr. (Lu) at 378:17–380:5; 381:1–381:14; 382:16–383:14; *see also* Tr. (Xiong) at 52:2–5. Mr. Lu testified that the metal coil had been prepared for use by Vego Garden according to its colors. *See id.* at 380:12–19. As Mr. Lu testified, after the rejection, there were between "600 to 700 tons of material in [Shun Chuen's] inventory," which put him in a difficult position. *See* Tr. (Lu) at 378:19–381:11 and 380:23–24. Mr. Lu further explained that "a lot of [Foshan Nahong's] cash" was required for ordering the inventory, putting Foshan Nahong in a position where it stood



## PUBLIC VERSION

to lose this money after Shun Chuen rejected the metal coil. *See id.* at 379:12–19. Thus, Mr. Lu decided to start Green Giant partly to recoup some of the losses incurred because of the rejection of materials. *See id.* at 379:21-25.

Within three weeks of Vego Garden and Shun Chuen’s rejection of the materials, *i.e.*, May 2021, Mr. Lu ordered a first flat panel machine and bending machine under the name of Green Giant. JX-0008C (Roll Forming Machine Technical Scheme), JX-0001 (Purchase Contract dated May 13, 2021), Tr. (Lu) at 383:15–21. By November 2021, Green Giant had developed its raised metal garden bed products. CX-0037 (Xiong-Xie conversation transcript).

The evidence shows that in his work for Foshan Nahong, Mr. Lu visited Shun Chuen “very often” to assist with the Vego Garden raised metal garden bed products. Tr. (Lu) at 378:7–16. In that capacity, Mr. Lu obtained detailed knowledge about of Vego Garden’s raised metal garden bed products, including their manufacture. Tr. (Lu) at 378:7-16; Tr. (Xiong) at 52:12–52:17; 62:2–62:13; 67:7–16. He also established a relationship with Mr. Yu. Mr. Xiong testified as follows:

Q. Do Mr. Yu and Mr. Lu have a relationship?

A. Yes. When [Foshan Nahong] supplied metal material to [Shun Chuen], Mr. Yu and Mr. Lu, they have to communicate a lot. So they basically work together on all these projects.

Tr. (Xiong) at 52:12–15.

The evidence also shows that Mr. Lu had a relationship with Mr. Xiong and through that relationship had access to Vego Garden’s trade secret information, including its protective film information, *see* Tr. (Xiong) at 62:2–4, its bending machine, *see id.* at 67:14–16, and other details, *see generally* JX-0004 (WeChat transcript between Mr. Xiong and Mr. Lu). A WeChat conversation between Mr. Xiong and Mr. Lu shows they discussed wide-ranging issues, including the characteristics of paint needed to comply with North American standards, *see id.* at 5–8, and

## PUBLIC VERSION

the configuration of connecting rods used in Vego Garden's raised garden beds, *see id.* at 15–16. This evidence demonstrates that Mr. Lu was intimately familiar with Vego Garden's raised metal garden bed product and its trade secret information.

Mr. Lu's relationships with Mr. Yu and Mr. Xiong, because of his employment by Foshan Nahong, gave him access to Vego Garden trade secret information while under a confidentiality obligation. The evidence supports that Mr. Lu leveraged those relationships and used the confidential information he obtained from Mr. Yu and Mr. Xiong to start his competitor company, Green Giant. Mr. Lu was undoubtedly motivated use Vego Garden's trade secret information, after Vego Garden and Shun Chuen's the rejection of materials from Foshan Nahong, his loss of a commission, and the monetary harm to Foshan Nahong. Mr. Lu's deceptive behavior also supports that he misappropriated Vego Garden's trade secret that he obtained while employed by Foshan Nahong. In 2021, after Mr. Lu had founded Green Giant, he continued to represent Foshan Nahong in its dealings with Shun Chuen, and by extension Vego Garden. Tr. (Lu) 388:19-389:10. Mr. Lu never disclosed his relationship with Green Giant to Vego Garden, *id.* at 387:12-14; 388:19-24, and Mr. Xiong did not learn that Mr. Lu was actually a founder and the head of Green Giant until after this investigation was instituted. *See* Tr. (Xiong) at 203:18-205:2. This is despite the fact that Mr. Xiong and Mr. Lu were in regular communication through November of 2021. *See* JX-0004 at 34–36.

The record evidence supports that Mr. Lu wrongfully acquired Vego Garden's trade secret information.

#### **4. Wrongful Disclosure or Acquisition by Mr. Yu**

The evidence supports Vego Garden worked closely with Mr. Yu to use its trade secret information in Shun Chuen's manufacture of Vego Garden's raised metal garden bed products. Tr.

## PUBLIC VERSION

(Xiong) at 71:21–73:17 (Mr. Xiong testifying that Mr. Yu was Vego Garden’s “point of contact” at Shun Chuen and knew Vego Garden’s confidential information); *see also* Staff Post-Hearing Br. at 33. The evidence also supports that Vego Garden’s asserted trade secret information was disclosed to Mr. Yu in the context of a confidential relationship. *See, e.g.*, CX-0014; JX-0020; Tr. (Xiong) at 72:8–73:17; *see also* CX-0037 at Nos. 80–85 and section V.C.3.

And while Mr. Lu also had access to Vego Garden’s confidential information, he lacked the expertise necessary to produce raised metal garden bed products that would compete with Vego Garden’s products. CX-0500 (Lu Dep.) at 37:14–38:16, 22–23. For that reason, Green Giant recruited Mr. Yu to advise Green Giant on manufacturing issues. *See* CX-0037 at Nos. 70–74; Tr. (Xiong) at 72:14–73:17. Mr. Yu worked with Green Giant in June/July 2021 to help resolve issues with the machinery and to provide advice to Green Giant on how to make its raised metal garden bed products. CX-0037 at Nos. 68–75, 80–81.

Mr. Yu knew Mr. Xiong was the owner of Vego Garden, and apparently considered Mr. Xiong a prospective customer for Green Giant, which was looking for customers for its raised metal garden bed products. *See* Tr. (Xiong) at 52:18–53:4. In November 2021, Mr. Yu introduced Mr. Xiong to Mr. Xie, a co-owner of Green Giant. *See id.* When Mr. Yu told Mr. Xiong that Mr. Xie could supply him with “the same garden beds” that Vego Garden was selling, Mr. Xiong was “very shocked.” *See id.* at 53:7–11. After this, Mr. Xiong decided to call Mr. Xie. *See id.* at 53:11–12. Mr. Xiong recorded the conversation with Mr. Xie, and a translation of this recording was admitted into evidence as CX-0037.

## PUBLIC VERSION

Respondents contend that CX-0037 should not be considered. Respondents Post-Hearing Resp. Br. at 26.<sup>21,22</sup> Respondents argue that the recording is “problematic, and no reasonable fact finder would find in Complainant’s favor solely based on this problematic recording.” Respondents Post-Hearing Br. at 23. Respondents in particular argue that it “does not make sense if Mr. Xie is truly the founder of Green Giant purported to be, if this is true, why would Xie accuse the real founder of Green Giant, Mr. Lu stating ‘we were tricked by Lu of Nahong, he passed us a whole bunch of all his inventory, we had no choice but work on it now, we were forced.’” *Id.*, quoting CX-00037 at No. 23. Until this investigation was instituted, however, Mr. Xiong did not know Mr. Lu had started Green Giant as a competitor to Vego Garden. Tr. (Xiong) at 203:8–205:2. The evidence demonstrates that it was in Green Giant’s interest to maintain this deceit so that Mr. Xiong and Vego Garden would continue unabated its relationship with Shun Chuen (and its engineer, Mr. Yu) and Shun Chuen’s supplier, Foshan Nahong (and Mr. Lu) so that Mr. Lu could sell the inventory that Vego Garden and Shun Chuen had rejected.

Respondents also contend that CX-0037 is unreliable, stating that “[i]t is undeniably [sic] that Mr. Xie could essentially say whatever he wanted, which could not be afforded the presumption of reliability.” Respondents Post-Hearing Resp. Br. at 26, citing *United States v. Pazsint*, 703 F.2d 420, 424 (9th Cir. 1983) and *AAMCO Transmissions, Inc. v. Baker*, 591 F. Supp.

---

<sup>21</sup> Respondents did not object to CX-0037 during the hearing and have thus waived any objection to its admissibility. See Tr. (Xiong) at 53:20–54:12.

<sup>22</sup> Respondents also appear to contend that there are translation issues with CX-0037. Respondents Post-Hearing Resp. Br. at 29–30. To the extent that Respondents now dispute Vego Garden’s translation, the Ground Rules require that “[i]f a party disputes the translation provided by the producing party, the translation must be certified by a qualified and neutral translator agreed on by the parties.” Order No. 14 at Ground Rule 6.8. Respondents did not timely dispute the translation of CX-0037 and have waived their right to do so.

**PUBLIC VERSION**

2d 788, 799 (E.D. Pa. 2008). In *Pazzint*, the court excluded tape-recorded emergency calls because the witnesses who gave the information which was recorded had personal knowledge but were under no business duty to report. 703 F.2d at 425. Therefore, the tape-recorded statements did not qualify for the business record exception to the hearsay rule. *See id.* In *AAMCO*, the court excluded audio-recordings and related memoranda when shoppers' statements to investigators similarly did not qualify under an exception to the hearsay rule. *See* 591 F. Supp. 2d at 794–800.

Respondents thus rely on selected decisions regarding the admissibility of hearsay evidence. The problem is that Mr. Xie's statements on the recording are not hearsay. Mr. Lu testified at his deposition as follows:

Q. Okay. You had testified earlier that you own 80 percent of Green Giant; is that correct?

A. Correct.

Q. Who owns the other 20 percent?

A. I actually own, I would say -- technically, I own 90 percent of the company. The other 10 percent on the paper belongs to the person with the last name Xie, because the attorney advised that I should just put it on paper the way we agreed on, but that 10 percent never materialized. And then also, there is another 10 percent that belongs to my nephew Yuxiang Lu.

CX-0500 (Lu Dep.) at 85:20–86:6.

Thus, based on the testimony of Mr. Lu, CX-0037 is a recording of a co-owner of Green Giant.<sup>23</sup> Because that recording was offered against Green Giant, it is not hearsay under Rules 801(d)(2)(A) or (D). *See* Fed. R. Evid. 801(d); *Barnes v. Owens-Corning Fiberglass Corp.*, 201

---

<sup>23</sup> Respondents contend that “[f]rom the recording, it appears that Mr. Xie was not the founder of Green Giant, as he was trying to frame.” Respondents Post-Hearing Br. at 24. Respondents also question whether Mr. Xie “was truly from Green Giant.” Respondents Post-Hearing Resp. Br. at 30. Respondents’ arguments notwithstanding, the evidence is clear that Mr. Xie is a co-owner of Green Giant.

## PUBLIC VERSION

F.3d 815, 828–29 (6th Cir. 2000) (“Of course, under Fed. R. Evid. 801(d)(2)(A), a party’s own statement that is offered against him is ‘not hearsay.’”); *Browe v. CTC Corp.*, 15 F.4th 175, 207–08 (2d Cir. 2021) (“Rule 801(d)(2)(D) defines as non-hearsay any statement offered against a party made ‘by the party’s agent or employee on a matter within the scope of that relationship while it existed.’”).

Respondents further argue that they lacked the opportunity to depose Mr. Xie. Respondents Post-Hearing Resp. Br. at 26. Mr. Xie, however, is a co-owner of Green Giant and Respondents have failed to address why they did not present evidence from him. In any event, assuming *arguendo* that Mr. Xie was unavailable to testify (something never argued by Respondents), the recording is also admissible under Rule 804(b)(3)(A). *See* Fed. R. Evid. 804; *Roe v. Howard*, 917 F.3d 229, 246–47 (4th Cir. 2019) (“Rule 804(b)(3) authorizes the admission of hearsay statements by an unavailable declarant that are manifestly against the declarant’s interest. Specifically, the statement must be one that ‘a reasonable person in the declarant’s position would have made only if the person believed it to be true because, when made, it ... had so great a tendency ... to expose the declarant to civil or criminal liability.’”).

Respondents further contend that Vego Garden never specifies the information that was obtained from Mr. Yu. Respondents Post-Hearing Br. at 23; *see also* Respondents Post-Hearing Resp. Br. at 27. The evidence supports that Mr. Yu provided a substantial amount of Vego Garden confidential information to Green Giant, including, at least, drawings. When asked if the drawings for Green Giant’s products were consistent with those for Vego Garden’s products, Mr. Xie stated that they “should more or less be the same.” CX-0037 at Nos. 68–71. Mr. Xie further stated that “a lot of data was also provided by” Mr. Yu. *Id.* at No. 71. The following additional excerpts from

**PUBLIC VERSION**

CX-0037 also demonstrate that Mr. Yu provided substantial confidential information to Green Giant to address the problems Green Giant was having in manufacturing its products:

[Mr. Xiong]: How would I put this, we have the demand, but after all, we know very little about you. And there is someone we both know of. Anyways, Yu Xiong said that he knew you, and I trust Yu Xiong in terms of his technical skills.

[Mr. Xie]: We were like this. . . When we first started researching this project, as matter of fact, Yu Xiong did give us some constructive suggestions, including how to do the planning and sorting things out, including quite a bit of suggestions to be used on the system. In fact, we just entered this industry, up until now, a lot of stuff are done in reference to his standards.

[Mr. Xiong]: As to the corrugating process, that has certain threshold we really had to work hard to pass. It also took Yu Xiong quite some time to get the hang of it last year. Slowly we were finally able to get the right stuff.

[Mr. Xie]: In fact, if starting from scratch all by ourselves, in terms of the time, let me calculate it for you, three months are not enough, not enough at all. Not to mention anything else, even if you ask your friends to design and develop this equipment, you would not have enough time. To be honest, no matter how great your skills are, it is still very easy to walk on the wrong path and waste time. Let's just be frank. We might have got a lot of ideas and suggestions from other people, but we still could not be clear about what we should do. We have done 90% of it, we were almost there, but not quite, we could just miss a little bit there, it is possible we might have achieved 99% of the work, then 100%. To us, Yu Xiong was that special helpful man. To tell you the truth, he did help us a lot, right.

CX-0037 at Nos. 80–85.

Thus, while Respondents point to certain contents of the recording, Respondents Post Hearing Resp. Br. at 25–29, and contend that Mr. Xie is “nothing but a con artist,” and a “salesman who will employ [sic] whatever strategy necessary to lure the customers and receive the commission,” *id.* at 30, they do not refute that Mr. Xie stated, among other things, that Mr. Yu

**PUBLIC VERSION**

gave “some constructive suggestions,” “a lot of stuff are done in reference to his standards,” and was “that special helpful man” who “help[ed] us a lot.” CX-0037 at Nos. 81 and 85. Further, Mr. Xiong testified that after his discussion with Mr. Xie, in which he learned that Mr. Xie asked for Mr. Yu’s help in developing Green Giant’s raised metal garden bed products, he was “very concerned” that Mr. Yu had disclosed Vego Garden confidential information to Green Giant. Tr. (Xiong) at 73:12–17.

In addition, the evidence demonstrates that Green Giant’s products duplicate those of Vego Garden.



CX-0019 (Green Giant catalog)



**PUBLIC VERSION**



CX-0069 (Vego Garden Raised Garden Beds)

*Compare CX-0019 (Green Giant catalog) with CX-0065, CX-0066, CX-0067, CX-0068, CX-0069 (collectively, images of Vego Garden raised garden beds). As Mr. Xie admitted in his conversation with Mr. Xiong, “[I]f starting from scratch all by ourselves, in terms of the time, let me calculate it for you, three months are not enough, not enough at all. Not to mention anything else, even if you ask your friends to design and develop this equipment, you would not have enough time.” CX-0037 at No. 85. Given that Green Giant indeed managed to “design and develop th[e] equipment” within three months, the only reasonable conclusion based on the evidence is that Green Giant (including Mr. Lu) wrongfully obtained Vego Garden’s trade secret information from Mr. Yu. See Tr. (Xiong) at 52:18–53:12; and Tr. (Lu) at 387:24–388:24.*

The evidence thus strongly supports that Vego Garden confidential information was wrongfully provided by Mr. Yu to Green Giant. This includes at least the asserted trade secret information. As to the 8-inch product development trade secret, given Mr. Yu’s employment by Shun Chuen, which manufactures Vego Garden’s products, and his role as the Shun Chuen “point person” for Vego Garden, the evidence supports that when Mr. Xiong discussed Vego Garden

## PUBLIC VERSION

introducing such a product to the market with Shun Chuen, Tr. (Xiong) at 75:18–76:1, Mr. Yu would have received that information. Respondents’ immediate entry into the market with an 8-inch product, including Utopban’s confirmation that upon introduction it alone had such a product, supports that Mr. Yu wrongfully disclosed Vego Garden’s 8-inch product development trade secret to Green Giant.

As to Vego Garden’s protective film information, the evidence demonstrates that Vego Garden worked with Shun Chuen to select its film, Tr. (Xiong) at 61:6–8, supporting that Mr. Yu had access to this information. As noted, however, the evidence does not support that this was protectable trade secret information.

And as to Vego Garden’s bending machine trade secret information, the evidence supports that Shun Chuen (and thus Mr. Yu) had access to this information and used the bending machine developed by Mr. Xiong to manufacture Vego Garden’s products. Tr. (Xiong) at 62:14–66:10; and CX-0060. The evidence also supports that Green Giant recruited Mr. Yu to help with its manufacturing issues, after which, those issues were resolved, and Green Giant was able to introduce its products to the market and file a patent application directed to Vego Garden’s bending machine improvements. The evidence thus supports that Mr. Yu wrongfully disclosed Vego Garden’s bending machine trade secret to Green Giant.

### **C. Use of the Asserted Trade Secrets**

“Use” of a trade secret occurs “when goods that embody a trade secret are marketed, the trade secret is employed in manufacturing or production, or is relied on to assist or accelerate research or development.” *Crawler Cranes*, Initial Determination, at 26–27, *citing* Restatement (Third) of Unfair Competition § 40, comment c. “An actor is liable for using the trade secret with

## PUBLIC VERSION

independently created improvements or modifications if the result is substantially derived from the trade secret.” *Id.*

Vego Garden contends that the asserted trade secrets are used in the manufacture of Green Giant’s raised garden bed products. Complainant Post-Hearing Br. at 32. Complainant argues that the rapid pace of development and commercialization for Green Giant’s products would have been impossible without the use of Vego Garden’s trade secrets. *See id.* This is further confirmed by the striking similarity between Green Giant’s products and those of Vego Garden. *See id.* Except for the protective film trade secret, Staff agrees with Complainant that the confidential trade secret information that Green Giant wrongfully acquired was in fact used to accelerate the time it took Green Giant to bring viable products to market. *See Staff Post-Hearing Br. at 38.*

Respondents contend that Green Giant’s products were developed independently, without reference to Vego Garden’s trade secrets. Respondents Post-Hearing Br. at 34–36. Respondents in particular submit that reverse engineering is common in the raised garden beds industry, and that Vego Garden has also reverse engineered other brands’ products. *Id.* at 35, *citing* Tr. (Lu) at 339:3–9. Respondents argue that these products are simple in design, and well-known in the industry. *See id.* at 35–36, *citing* Tr. (Lu) at 339:3–9, 364:17–365:18. Hence, Respondents argue that they were able to develop the accused products using publicly available information and/or non-confidential information. *Id.* at 24–27.

The evidence supports that Green Giant benefited from its misappropriation and use of Vego Garden trade secrets. As discussed above in the context of misappropriation, the evidence shows that Green Giant misappropriated Vego Garden’s trade secret information and used that information, including drawings, provided by Mr. Yu, in the development and manufacture of its products. *See CX-0037 at Nos. 68–73, 81, 85.* Respondents fail to rebut Vego Garden’s evidence

## PUBLIC VERSION

showing that the design and manufacture of Green Giant's products were derived from Vego Garden's trade secret information.

### **1. The 8-Inch Product Development Research Trade Secret**

Respondents argue that Green Giant launched its 8-inch product because it independently found that there was a market for such product, and that it could produce this product at a reduced price due to its smaller size. *See* Respondents Post-Hearing Br. at 24–25. However, Vego Garden presented evidence showing that it took approximately a year to engage in the research and development necessary to produce its 8-inch raised garden bed. *See* Complainant Post-Hearing Br. at 24, *citing* Tr. (Xiong) at 57:24–59:1. Moreover, Utopban's corporate representative, Mr. Li, testified that there was no 8-inch product available on the market before it was introduced by Respondents. *See* CX-0501 (Li Dep.) at 45:1–13. The Staff agrees with Vego Garden that Green Giant misappropriated and used Vego Garden's trade secret. *See* Staff Post-Hearing Br. at 38. Other than the unreliable testimony of Mr. Lu, Green Giant has provided no evidence showing that it developed its own 8-inch raised metal garden bed. *See* Respondents Post-Hearing Br. at 24–25, *citing* Tr. (Lu) 357:2–25, 358:15–24; and CX-0500 (Lu Dep.) at 29:13–24.

Given that it took Vego Garden approximately one year to research and develop its 8-inch garden bed, and that Green Giant was able to beat Vego Garden to the market with its own 8-inch garden bed that it developed in three months, I find that the evidence supports that Green Giant used Vego Garden's 8-inch product development trade secret.

### **2. The Protective Film Trade Secret**

Vego Garden argues that Mr. Lu frequently visited Shun Chuen and knew about the film Shun Chuen used for Vego Garden's products. Complainant Post-Hearing Br. at 22, *citing* Tr. (Lu) at 378:7–16; Tr. (Xiong) at 52:12–17, 62:2–13. Vego Garden further argues that it would take a

## PUBLIC VERSION

competitor approximately a year of research and development to select the correct film. *See id.* at 25, *citing* Tr. (Xiong) at 76:20–25; Tr. (Beaman) at 408:10–17, 408:23–409:11. Given that Green Giant was able to enter the market in three months, Vego Garden contends that Respondents must have relied on Vego Garden’s trade secret information. *See id.* at 32.

Respondents contend that Vego Garden has failed to show that Green Giant uses the same film as Vego Garden. *See* Respondents Post-Hearing Br. at 25. Respondents further argue that there can be no trade secret misappropriation as both Vego Garden and Green Giant obtain their respective films from different third parties. *See id.* at 26. The Staff agrees with Respondents that Vego Garden has not proven use of the asserted protective film trade secret. *See* Staff Post-Hearing Br. at 38, n.16.

As discussed above, Vego Garden has not shown that its protective film trade secret is a protectable trade secret. *See* section V.D. Because Vego Garden does not identify the film it uses and does not identify the film Green Giant uses, Vego Garden has not demonstrated use by the Respondents of its asserted protective film trade secret.

### **3. The Bending Machine Trade Secret**

Respondents argue that the metal-forming machine was also available to purchase from third-party factories and suppliers. *See* Respondents Post-Hearing Br. at 26. Vego Garden, however, presented evidence showing that Green Giant obtained assistance in addressing its manufacturing issues from Vego Garden’s “point of contact” at its manufacturer Shun Chuen. In fact, Mr. Xie admitted to Mr. Xiong that Mr. Yu was “that special helpful man” who guided the development of Green Giant’s manufacturing process. *See* CX-0037 at No. 85. In addition, as Dr. Beaman testified, Green Giant’s bending machine appears to be nearly identical to that of Vego Garden’s. *See* Tr. (Beaman) at 406:16–21; *compare* JX-0009 with JX-0021.

## PUBLIC VERSION

Green Giant was able to develop its own manufacturing process in three months, whereas it took Vego Garden approximately a year to do the same. *See* Tr. (Xiong) at 66:14–67:6; CX-0037 at No. 27. Green Giant’s Mr. Xie admitted to Mr. Xiong, during the recorded conversation, that Green Giant relied on information provided by Mr. Yu:

[Mr. Xiong]: Ok. We don’t need to hide anything. If it is the drawings that Yu Xiong gave to you, then they should be the same. If the drawings are not the same, it wouldn’t be possible that we ask you to make the products (for us).

[Mr. Xie]: They should be more or less the same, because a lot of data was also provided by him. In other words, they are within the industry, you know. It is a very small circle, you know, and all products are more or less the same. Products such as the nine in one, are basically the same.

[Mr. Xiong]: Nine-in-one ... , but this is our own naming method. Do you also call that nine-in-one?

[Mr. Xie]: More or less. You are the benchmark in the industry. Everyone in the industry has more or less the same thing.

CX-0037 at Nos. 70–73.

In addition, the extensive similarities between the corner panels of Vego Garden’s products and those of Green Giant are circumstantial evidence of use of Vego Garden’s trade secret information. *Compare* CX-0019 (Green Giant catalog) *with* CX-0065, CX-0066, CX-0067, CX-0068, CX-0069 (images of Vego Garden raised garden beds).

“A claim of trade secret misappropriation is broad enough to encompass modifications or improvements to a product or process, when such modifications or improvements are derived from the asserted trade secrets.” *Certain Steel Railway Wheels, Processes for Manufacturing or Relating to Same and Certain Products Containing Same*, Inv. No. 337-TA-655, USITC Pub. No. 4256 (Oct. 2011), Initial Determination at 46 (Oct. 16, 2009), *unreviewed in relevant part* by Comm’n Notice (Dec. 17, 2009), *affirmed by TianRui*, 661 F.3d 1322. Vego Garden has shown that the

## PUBLIC VERSION

improvements it made to bending machine technology were its trade secret. The evidence also demonstrates that Green Giant had access to Vego Garden's bending machine trade secret and recruited Mr. Yu to assist with its manufacturing issues. The only reasonable conclusion from the evidence is that Green Giant used Vego Garden's misappropriated bending machine trade secret information when developing its own bending machine and continued using that trade secret information when manufacturing its products.

### **VII. RESPONDENTS' AFFIRMATIVE DEFENSE OF INDEPENDENT DEVELOPMENT**

Respondents contend that they independently developed their raised metal garden bed products without reference to Vego Garden's trade secrets. Respondents' Post-Hearing Br. at 35–36. A respondent bears “a heavy burden” in proving independent development. *Sausage Casings*, Inv. Nos. 337-TA-148/169, Initial Determination at 247.

In contending that “the evidence shows that Green Giant developed the raised garden bed products independently, without reference to Complainant's trade secrets,” Respondents point to May 2021 agreements with third parties to purchase equipment and materials. Respondents Post-Hearing Br. at 35, *citing* JX-0001<sup>24</sup> (Equipment Purchase Agreement); JX-0007C (Xiamen Brandnew Metal Co. Specifications); and JX-0008C (Xiamen Brandnew Metal Co. Specifications). Those documents, however, do not demonstrate independent development of Vego Garden's trade secrets. Instead, they show that Respondents were taking steps to manufacture competing raised metal garden bed products.

---

<sup>24</sup> Respondents identify this document as JX-0001C. Respondents Post-Hearing Br. 35. It was labeled as JX-0001.

## PUBLIC VERSION

And despite these agreements, the evidence shows that Green Giant could not find equipment manufacturers to make the equipment it needed. CX-0037 at No. 67 (“Because the equipment cannot be found. I found many factories to help and none of them could make it”). Instead, at the time Respondents contend Green Giant was involved in independent development, Green Giant needed the help of Mr. Yu. *Id.* at No. 85 (“To us, Yu Xiong was that special helpful man. To tell you the truth, he did help us a lot, right.”). As noted in *Sausage Casings*, evidence that necessary information could not be provided by the party asserting independent development does not meet the “heavy burden of persuasion” that the design “was the result of independent development.” Inv. Nos. 337-TA-148/169, Initial Determination at 284–285. That is the case here. At the very time Respondents contend Green Giant was engaged in independent development, Green Giant was having difficulty finding an equipment manufacturer and needed the help of Mr. Yu to manufacture its own raised metal garden bed products.

Respondents also contend that “Vego’s manufacturer admitted that the raised metal garden beds are ‘reverse engineerable.’” Respondents Post-Hearing Br. at 35, *citing* Tr. (Lu) at 339:3–9. Respondents grossly mischaracterize the cited testimony. Instead of an admission by Vego Garden’s manufacturer, Shun Chuen, Mr. Lu testified that Vego Garden “approached Shunchuan for the manufacturing of the product, but because Shunchuan also did not know how to do it, how to make it, so they reverse-engineered this product.” *Id.* In the face of the evidence demonstrating that Green Giant (and Mr. Lu) had to rely on Mr. Yu to manufacture its products, Mr. Lu’s testimony that Shun Chuen reverse engineered Vego Garden’s products is not credible.

Respondents also point to the testimony of Mr. Lu regarding the alleged prevalence of reverse engineering in China. Respondents Post-Hearing Br. at 35, *citing* Tr. (Lu) at 364:19–23 (Q. In your opinion, is raised garden beds easy to reverse-engineer? A. Well, it is not just me. I



## PUBLIC VERSION

believe in the entire country, in China, this is a very easy thing to do. And that's why it only took me very, very little time to give a quote to Shunchuan when they first approached me asking whether I was able to manufacture the panels.”). Even accepting *arguendo* that reverse engineering is a common practice in China, Respondents have failed to meet their burden to demonstrate independent development of Vego Garden's trade secrets.

Respondents also cite generally to the deposition testimony of Dr. Beaman for the proposition that certain of the trade secrets are “reverse engineerable.” Respondents Post-Hearing Br. at 36, *citing* RX-0500. Whether or not that broad proposition is true does not suggest, let alone demonstrate, that Green Giant independently developed Vego Garden's trade secrets.<sup>25</sup>

Based on the record evidence, Respondents have failed to carry their “heavy burden” in demonstrating independent development.

### VIII. UNFAIR COMPETITION

Vego Garden asserts that Utopban has violated Section 337 by importing into the United States and/or selling the accused products through unfair competition. In particular, Vego Garden contends that Utopban engaged in false advertising under 15 U.S.C. § 1125(a)(1)(B) by using Vego Garden's photographs as false representations of its own products.<sup>26</sup> Amended Complaint,

---

<sup>25</sup> Respondents also contend that “there is a lot of information about these products available online.” Respondents Post-Hearing Br. at 36. As discussed above, Respondents have not shown that the 8-inch product development trade secret or the bending machine trade secret were known outside of Vego Garden. *See* sections V.C.1 and V.E.1.

<sup>26</sup> To the extent that Respondents identify Vego Garden's claim as one of copyright infringement, that is incorrect. *See* Respondents *Abitron* Resp. Br. at 3 (EDIS Doc. ID 802351). The Commission instituted this investigation “to determine whether there is a violation of subsection (a)(1)(A).” 87 Fed. Reg. 63527. A claim of copyright infringement is cognizable under 19 U.S.C. § 1337(a)(1)(B).

## PUBLIC VERSION

¶¶ 6.1–6.6;<sup>27</sup> Complainant Pre-Hearing Br. at 21–26 (identifying allegations of false advertising against Utopban); and Complainant Post-Hearing Br. at 32–37 (same). The Staff agrees that Utopban has engaged in false advertising in violation of the Lanham Act, 15 U.S.C. § 1125(a)(1)(B). Staff Post-Hearing Br. at 39–48.

Utopban did not address or challenge Vego Garden’s false advertising allegations in its pre-hearing brief. *See* Respondents Pre-Hearing Br.; Staff Post-Hearing Br. at 40; and Staff Post-Hearing Resp. Br. at 13. Under Ground Rule 11.2, “[a]ny contention not described in detail in the pre-hearing brief shall be deemed abandoned or withdrawn, except for contentions a party is not aware of and could not be aware of in the exercise of reasonable diligence when the pre-hearing brief was filed.” Order No. 14 (Mar. 9, 2023) (EDIS Doc. ID 792150). Utopban does not contend that it was unaware of Vego Garden’s allegations of false advertising against it, nor could it, as those allegations were plainly made in Vego Garden’s Amended Complaint. Amended Complaint, ¶¶ 6.1–6.6. Because Utopban did not substantively address or contest Vego Garden’s false advertising allegations in its pre-hearing brief, I find that Utopban has waived this issue.

### **A. Vego Garden’s False Advertising Claim Is Not Moot**

Despite failing to address Vego Garden’s false advertising claim in its pre-hearing brief, Utopban contends that “[t]his is not an issue before the Commission since it is mooted,” *i.e.*, the issue is moot because Utopban has stopped using Vego Garden’s photographs. Respondents Post-Hearing Resp. Br. at 31–32; *see also* Staff Post-Hearing Br. at 40, n.17; Respondents Post-Hearing Br. at 27; and Respondents *Abitron* Resp. Br. at 2–3.

---

<sup>27</sup> Vego Garden’s allegations of unfair competition in its Amended Complaint are made against “Vegega.” *See id.* Utopban has admitted that it does business under the name “Vegega.” Utopban Response to Amended Complaint, ¶ 3.2.

## PUBLIC VERSION

The ability of the Commission to consider an allegation “does not terminate upon the cessation of the unfair act.” “[I]f that were the case, any respondent could defeat Commission section 337 jurisdiction [before] the conclusion of an investigation by ceasing importation of the subject merchandise, avoid the consequences of the violation, and then begin importing again once the 337 investigation was terminated.” *Certain Molded-In Sandwich Panel Inserts and Methods for Their Installation*, Inv. No. 337-TA-099, USITC Pub. No. 1297, Comm’n Op. at 16 (Oct. 1982) (EDIS Doc. ID 235410). As a result, even if Utopban has stopped using the photographs forming the basis of Vego Garden’s false advertising claim, that claim is not moot.

### **B. Vego Garden Owns the Photographs Utopban Used on Its Website and Instagram**

Vego Garden contends that it owns certain photographs of its products and that “Utopban introduced its products—and thereafter continued to market such products—in the United States through violations of the Lanham Act, 15 U.S.C. § 1125 (2022)” by “copying photographs of Vego’s products and using such photographs to promote Utopban’s products through its website and Instagram account.” Complainant Post-Hearing Br. at 1.

The evidence demonstrates that Vego Garden owns the photographs of its products. Tr. (Xiong) at 36:18–21 (Vego Garden uses its farm for photographs on its website and social media); 54:16–18 (Vego Garden has an Instagram account with photographs of its raised garden bed products). This is not disputed by Utopban. Indeed, Mr. Li, the general manager of Utopban, Tr. (Li) at 310:7–14, testified that when its raised garden bed business first started, Utopban “didn’t have any good looking photos” but “wanted to show the scenarios where these garden beds can be used at or in.” CX-0501 (Li Dep.) at 50:21–24. To accomplish this, a Utopban employee found the

## PUBLIC VERSION

Vego Garden photographs and used them to “illustrate the [Utopban] products’ use case, our products’ use case.” Tr. (Li) at 312:11–22.

Mr. Li also testified that Utopban did not use Vego Garden’s photographs until March or April 2022, Tr. (Li) at 318:3–7, but the evidence demonstrates Utopban’s use on its Instagram account at least as early as February 2022. CX-0073 (showing a date in February 2022); and SX-0008.001 (same). Mr. Li agreed that Utopban’s use of Vego Garden’s photographs was so that customers would buy Utopban’s products. Tr. (Li) at 319:3–9. He also testified that in August 2022, users from Utopban’s Instagram account alerted Utopban and “asked us why are we using someone else’s photo to illustrate our own product?” at Tr. (Li) at 312:23–25. He testified that he immediately instructed his employees to stop using Vego Garden’s photographs after being alerted by those users. *Id.* at 313:1–4.

Based on the record evidence, I find that Vego Garden owns the photographs Utopban used in its advertising.

### **C. Utopban Engaged in False Advertising**

Utopban placed its first order with Green Giant for raised metal garden bed products around the first quarter of 2022. CX-0501 (Li Dep.) at 77:17–25. The evidence demonstrates that at least as early as February 2022, Utopban used Vego Garden’s photographs on its website and Instagram to advertise Respondents’ products. Tr. (Li) at 317:22–319:2; CX-0073; SX-0008.001. Utopban stopped using Vego Garden’s photographs to advertise its products in August 2022. *Id.* at 312:23–313:7. The complaint in this investigation was filed in September 2022. 87 Fed. Reg. 63527.

Under the Lanham Act, it is unlawful to use in commerce, in connection with goods or services, any “false or misleading description of fact, or false or misleading representation of fact . . . in commercial advertising . . . [which] misrepresents the nature, characteristics, qualities, or

## PUBLIC VERSION

geographic origin of his or her or another person's goods, services, or commercial activities." 15 U.S.C. § 1125(a)(1)(B). False advertising is recognized as a form of unfair competition under 19 U.S.C. § 1337(a)(1)(A). *Food Processing Equipment*, Inv. No. 337-TA-1161, Initial Determination at 14.

To succeed on a Lanham Act claim of false advertising, the complainant must prove:

- (1) The respondent made false or misleading statements about their own or another person's product;
- (2) There is actual deception or at least a tendency to deceive a substantial portion of the intended audience;
- (3) The deception is material in that it is likely to influence purchasing decisions;
- (4) The entry of the false advertisement into interstate commerce; and
- (5) There is a likelihood of injury to the complainant because of the false statement.

*See Certain Cigarettes and Packaging Thereof*, Inv. No. 337-TA-424, USITC Pub. No. 3366, Initial Determination at 43 (Jun. 22, 2000) (*Cigarettes*), *unreviewed by*, Comm'n Notice (Aug. 28, 2000) (EDIS Doc. ID 52778).

As noted, Respondents do not dispute the merits of Vego Garden's false advertising claim. Nonetheless, I address each of the factors below.

### **1. Utopban Made False Statements**

To show a false or misleading statement, "the complainant must prove that the advertisement is 'either (1) literally false, or (2) literally true or ambiguous but likely to mislead or deceive consumers.'" *Food Processing Equipment*, Inv. No. 337-TA-1161, Initial Determination at 15. An advertisement is "'literally false' if the message is both (1) unambiguous and (2) false." *Id.* In considering literal falsity, the factfinder must first identify the claim conveyed

## PUBLIC VERSION

in the advertising. Once the claim is identified, the factfinder must evaluate whether the claim is false. *Clorox Co. Puerto Rico v. Procter & Gamble Co.*, 228 F.3d 24, 34 (1st Cir. 1984). A literally false message can be “either (1) explicit or (2) conveyed by necessary implication when, considering the advertisement in its entirety, the audience would recognize the claim as readily as if it had been explicitly stated.” *Food Processing Equipment*, Inv. No. 337-TA-1161, Initial Determination at 15–16 (citations and quotations omitted). Whether a statement is literally false is a question of fact. *Certain Woven Textile Fabrics and Products Containing Same*, Inv. No. 337-TA-976, Initial Determination at 9 (Nov. 10, 2016) (EDIS Doc. ID 595428), *unreviewed by*, Comm’n Notice (Dec. 20, 2016) (EDIS Doc. ID 598632) (*Woven Textile Fabrics*).

I find that the claim conveyed by Utopban’s use of Vego Garden’s photographs in its advertising is that Vego Garden’s products are Utopban’s products. Side-by-side comparison of photographs on Vego Garden’s social media (on the left) and Utopban’s use of the very same photographs to advertise its products on its social media and on its website (on the right) demonstrate that Utopban was claiming that Vego Garden’s products were its own:

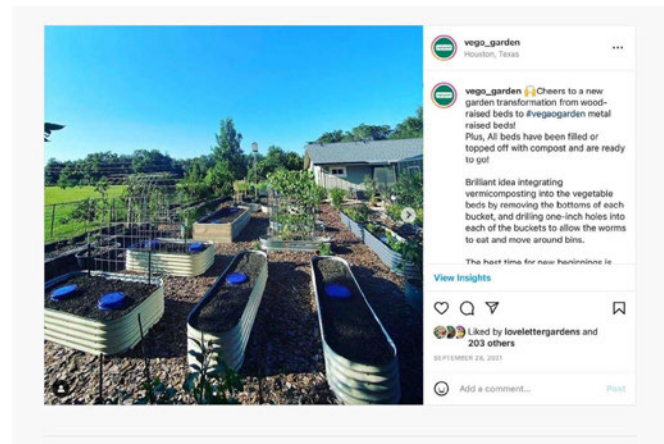

CX-0074 (image from Vego Garden Instagram)

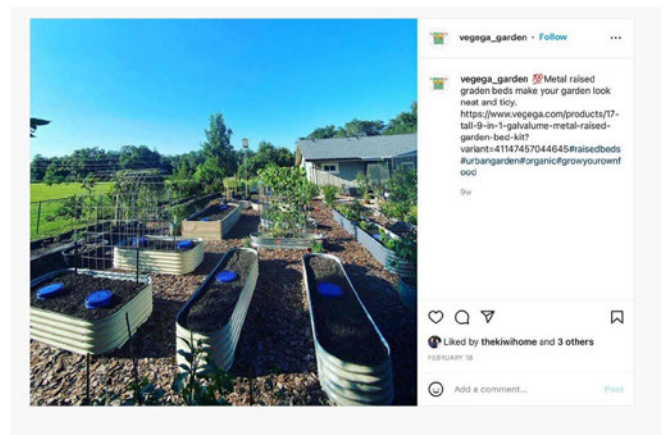

CX-0073 (image from Vegega Instagram)

PUBLIC VERSION



CX-0072 (image from Vego Garden Instagram)



CX-0071 (image from Vegega Instagram)

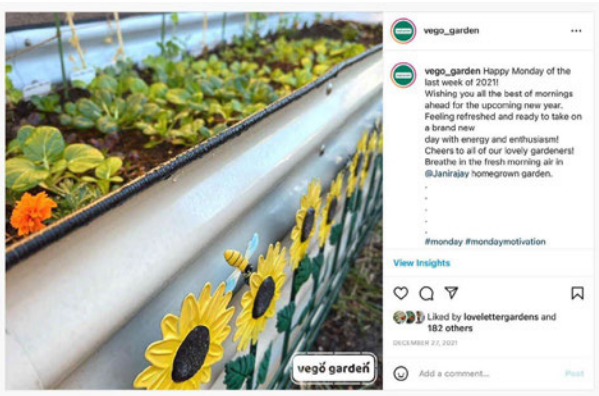

CX-0064 (image from Vego Garden Instagram)



SX-0008.001 (image from Vegega Instagram)

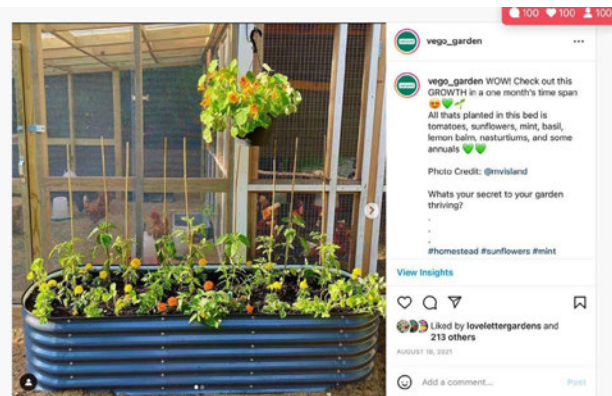

CX-0065 (image from Vego Garden Instagram)

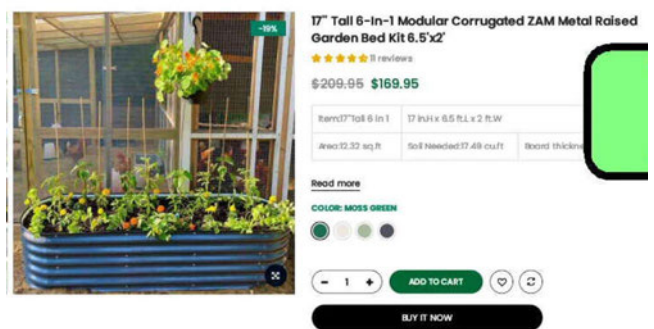

CX-0075 (image from Vegega website)

PUBLIC VERSION



CX-0066 (image from Vego Garden Instagram)

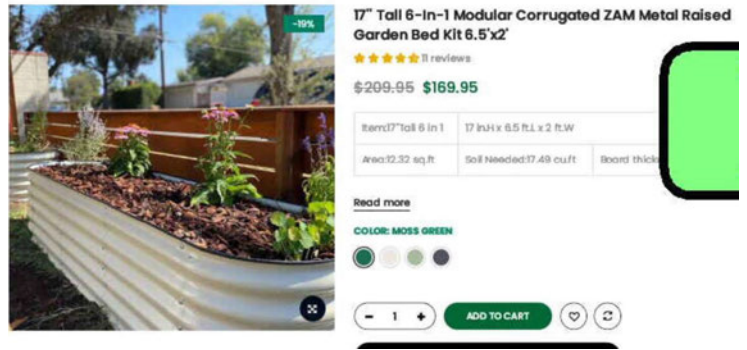

CX-0076 (image from Vegega website)

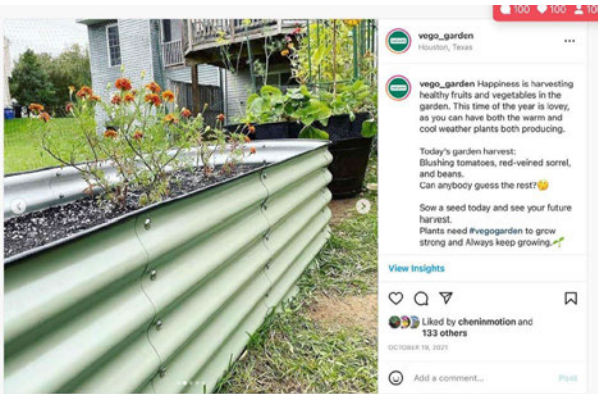

CX-0068 (image from Vego Garden Instagram)

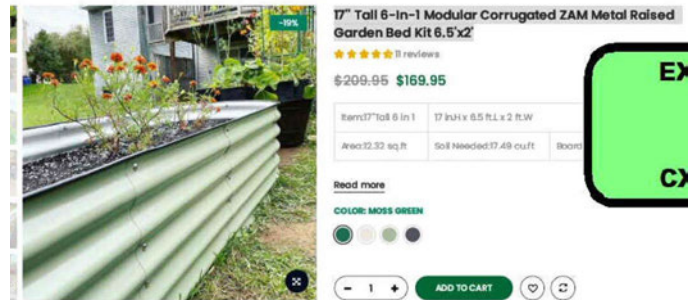

CX-0078 (image from Vegega website)



CX-0069 (image from Vego Garden Instagram)

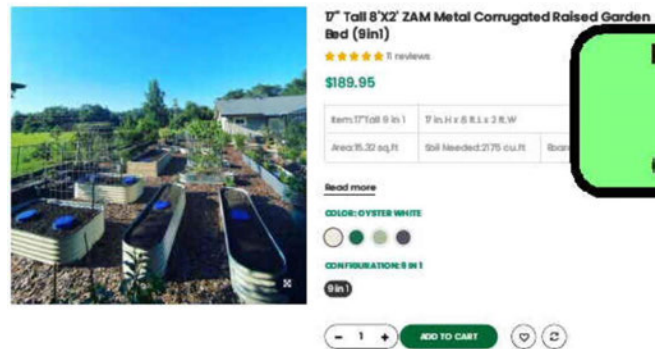

CX-0079 (image from Vegega website)

By its use of Vego Garden’s photographs, Utopban expressly represented that the Vego Garden product shown in the photograph was its own product. CX-0073 (showing a Vego Garden photograph on Vegega Instagram and stating the availability of a Vegega product at



## PUBLIC VERSION

“<https://vegega.com/products/17-tall-9-in-1-galvalume-metal-raised-garden-bed-kit>”); Complaint Ex. 3 (showing a Vego Garden photograph and stating, “vegega\_garden -- My mom told me she considered planting vegies on a metal raised bed. Should i tell HER i am selling this kind of products?”); CX-0075 (showing a Vego Garden photograph and stating that a “17” Tall 6-In-1 Modular corrugated ZAM Metal Raised Garden Bed Kit” is available from Vegega and identifying a U.S. address and telephone number); CX-0076 (same); CX-0078 (same); and CX-0079 (same).

To the extent Utopban’s use of Vego Garden’s photographs was not an express representation that Vego Garden’s products were its own products, that representation was conveyed by necessary implication. By using Vego Garden’s photographs as representations of what could be purchased from Utopban, Utopban conveyed by necessary implication that Vego Garden’s products were its products. *Food Processing Equipment*, Inv. No. 337-TA-1161, Initial Determination at 15.

Having determined the nature of Utopban’s claim, I next consider whether the claim was false. The Commission has considered this issue and concluded that “[u]se of the photograph of a competitor’s product to advertise another manufacturer’s product is false advertising.” *Certain Vertical Milling Machines and Parts, Attachments, and Accessories Thereof*, Inv. No. 337-TA-133, USITC Pub. No. 1512, Comm’n Op. at 41 (Mar. 1984) (EDIS Doc. ID 235415) (*Vertical Milling Machines*); see also *Certain Miniature Plug-in Blade Fuses*, Inv. No. 337-TA-114, USITC Pub. No. 1337 (Jan. 1983), Comm’n Op. at 32 (“Walter’s wrongful use of a picture of a Littelfuse fuse in its advertisement clearly constitute[s] false advertising”) (EDIS Doc. ID 235411) (*Plug-in Blade Fuses*); and *Ebeling & Reuss Co. v. Int’l Collectors Guild, Ltd.*, 462 F. Supp. 716, 720 (E.D. Pa. 1978) (use of the plaintiff’s photograph “is a false description or representation, actionable under the Lanham Act”).

## PUBLIC VERSION

There is no question, Utopban's representation that Vego Garden's products were its own products was false and there is no other plausible meaning that can be derived from that use. *Cf. Clorox*, 228 F.3d at 35 (a claim with several plausible meanings may not be characterized as literally false). The Vego Garden products are not Utopban products. Utopban does not dispute this. I find that the claim conveyed when Utopban used Vego Garden's photographs to advertise its own products was literally false.

### 2. Utopban's False Statements Were Deceptive

"If the statement is literally false, then the ALJ may grant relief without considering evidence of consumer reaction." *Food Processing Equipment*, Inv. No. 337-TA-1161, Initial Determination at 30 (internal quotations omitted); *see also Woven Textile Fabrics*, Inv. No. 337-TA-976, Initial Determination at 9, *citing Clorox*, 228 F.3d at 33. That is, proof of literal falsity relieves the complainant of its burden to prove actual consumer deception. *Groupe SEB USA, Inc. v. Euro-Pro Operating LLC*, 774 F.3d 192, 198 (3rd Cir. 2014).

Because Utopban's statements were literally false, Vego Garden was not required to prove consumer deception. Nonetheless, the record evidence demonstrates actual consumer deception. Through its use of Vego Garden's photographs, Utopban repeatedly and for months represented to customers and potential customers in the United States, either on its website or through its social media, that Vego Garden's products were its products. In particular, consumers who ordered through Utopban's website ([www.vegega.com](http://www.vegega.com)) believed they were ordering Vego Garden products because Utopban used Vego Garden's photographs. Mr. Guanyuan Xiong, the founder of Vego Garden, testified that Vego Garden customer service tickets show customer confusion between Vego Garden products and those marketed by Utopban under the Vegega name using Vego Garden photographs. Tr. (Xiong) at 55:6–57:12 (testifying about customer tickets; CX-0001;

## PUBLIC VERSION

CX-0002; and CX-0003). Vego Garden’s customer service tickets demonstrate consumer confusion because of Utopban using Vego Garden’s photographs. CX-0001 (Feb. 2022, Vego Garden responding to customer requesting order confirmation after placing an order through Utopban’s website (www.vegega.com): “We looked into Vegega and it looks like they are using most of our pictures from our site” and advising consumer to cancel their order with Vegega); CX-0002 (Apr. 2022, customer communicating with Vego Garden that “I ordered through vegega.com. Looks identical to your product” and “There [sic, their] pics of products are almost identical to yours. I hope its [sic] not a bait and switch situation”); CX-0003 (May 2022, from customer to Vego Garden: “After ordering I realized they were not from your company but from Vegega, a Chinese company. They seem to be the very same beds though” and noting the lower price of Utopban products). In addition, Mr. Li, the general manager of Utopban, testified that he was aware of instances in which customers were confused between Vego Garden products and products marketed by Utopban/Vegega. Tr. (Li) at 325:3–20. This was confirmed in an internal Utopban document. CX-0080C (from Utopban to consumer: “Ohh, I’m afraid that is not our order form. I think your [sic] purchase from vegogarden last year”).

I find that the record evidence supports that there was actual deception of a substantial portion of the intended audience.

### **3. Utopban’s False Statements Were Material**

If an advertisement is literally false, a court may grant relief “without considering evidence of consumer reaction,” including whether the false statement was material. *Southwest Recreational Indus., Inc. v. FieldTurf, Inc.*, 2002 WL 32783971 at \*3 (5th Cir. 2002) (“where a defendant has made literally false statements, the plaintiff need not demonstrate that the statements actually misled consumers, for we assume that false statements are materially deceptive”); *see also Johnson*

## PUBLIC VERSION

*& Johnson, Inc. v. GAC, Int'l, Inc.*, 862 F.2d 975, 977 (2d Cir. 1988) (“[w]hen a merchandising statement or representation is literally or explicitly false, the court may grant relief without reference to the advertisement’s impact on the buying public); *Clorox*, 228 F.3d at 33; *Certain Light Emitting Diode Products and Components Thereof*, 337-TA-947, Initial Determination at 435, n.60 (EDIS Doc. ID 589794) (July 29, 2016) (*Light Emitting Diodes*).

Because Utopban’s advertisements using Vego Garden’s photographs are literally false, materiality, like deception, may be presumed. The evidence nonetheless demonstrates that Utopban’s deception was “material in that it is likely to influence purchasing decisions.” *Woven Textile Fabrics*, Inv. No. 337-TA-976, Initial Determination at 14; *see also Food Processing Equipment*, Inv. No. 337-TA-1161, Initial Determination at 30. Mr. Li admitted that potential Utopban customers were in fact confused between Vego Garden’s and Utopban’s products. CX-0501 (Li Dep.) at 45:17–46:2; and CX-0080C. In addition, Vego Garden’s communications with several customers show that within the period Utopban admits it was using Vego Garden’s photographs, potential Vego Garden customers made decisions to purchase raised garden bed products from Utopban (Vegega) because Utopban used Vego Garden’s photographs. *See* CX-0001 (“they are using most of our pictures from our site”); CX-0002 (“There [sic] pics of products are almost identical to yours”); and CX-0003 (“They seem to be the very same beds”).

Based on the record evidence, I find that Utopban’s false statements were material in that they influenced purchasing decisions.

#### **4. Utopban’s False Advertisements Entered into Interstate Commerce**

As to interstate commerce, some cases have considered whether the false advertisement entered into interstate commerce. *Cigarettes*, Inv. No. 337-TA-424, Initial Determination at 43 (identifying the fourth factor as “the entry of the false advertisement into interstate commerce”),

## PUBLIC VERSION

citing *United Indus. Corp. v. Clorox Co.*, 140 F.3d 1175, 1180 (8th Cir. 1998) (“the defendant caused its false statement to enter interstate commerce”) and *Southland Sod Farms v. Stover Seed Co.*, 108 F.3d 1134, 1139 (9th Cir. 1997) (“the defendant caused its false statement to enter interstate commerce”); *Light Emitting Diodes*, Inv. No. 337-TA-947, Initial Determination at 431–32 (identifying the fourth factor as whether the “[t]he defendant placed the false or misleading statement in interstate commerce”); and *Certain Bearings and Packaging Thereof*, Inv. No. 337-TA-469, USITC Pub. No. 3736, Initial Determination at 153 (Dec. 2004) (EDIS Doc. ID 219734). The Ninth Circuit stated in *Southland* that before “the 1988 amendments to § 43(a), Pub. L. No. 100–667 § 132, 102 Stat. 3935, 3946, the interstate commerce requirement was associated with the defendant’s falsely advertised goods or services. After the 1988 amendments, it is the statement itself, rather than the falsely advertised goods or services, that must be used in interstate commerce.” 108 F.3d at 1139, n.3.<sup>28</sup>

Relevant to the interstate commerce requirement, after the parties submitted their post-hearing briefs, the Supreme Court issued its decision in *Abitron Austria GmbH v. Hetronic, Int’l, Inc.*, C.A. No. 21-1043, 2023 WL 4239255 (Jun. 29, 2023).<sup>29</sup> *Abitron* involved radio remote

---

<sup>28</sup> Other cases addressing false advertising under 15 U.S.C. § 1125(a)(1)(B) have considered whether the advertised good (as opposed to the advertisement) traveled in interstate commerce. *Food Processing Equipment*, Inv. No. 337-TA-1161, Initial Determination at 15 (identifying the fourth factor as whether “[t]he advertised good traveled in interstate commerce”); *Woven Textile Fabrics*, Inv. No. 337-TA-976, Initial Determination at 8 (identifying the fourth factor as whether “[t]he advertised good traveled in interstate commerce”); and *Groupe SEB USA, Inc. v. Euro-Pro Operating LLC*, 774 F.3d 192, 198 (3rd Cir. 2014) (identifying the fourth factor as whether “the advertised goods traveled in interstate commerce”). For the reasons explained below, based on the Supreme Court’s recent decision in *Abitron*, “use in commerce” refers to the advertisement. Nonetheless, the evidence demonstrates that Respondents’ raised metal garden bed products were imported into the United States and thus entered into interstate commerce. See section IV.

<sup>29</sup> I asked the parties to address the relevance and impact, if any, of *Abitron* to this investigation and have considered their briefs. See Request for Additional Briefing (EDIS Doc. ID 801611).

## PUBLIC VERSION

controls for construction equipment. Hetronic sold and serviced such products, which used a “distinctive black and yellow color scheme to distinguish them from those of its competitors.” Slip Op. at 1, *quoting* 10 F.4th 1016, 1024 (10th Cir. 2021). Hetronic sued Abitron for trademark infringement under 15 U.S.C. § 1125(a)(1) after Abitron began selling Hetronic-branded products, mostly in Europe, but also in the United States. After the Tenth Circuit affirmed a damages award that included “foreign infringing conduct,” Slip Op. at 3, the Supreme Court granted certiorari to consider whether 15 U.S.C. § 1125(a)(1) has extraterritorial application.

In its decision, the Court first recognized the presumption against extraterritorial application of U.S. laws and the “two-step framework” in applying that presumption. Slip Op. at 3. “At step one, [courts] determine whether a provision is extraterritorial, which determination turns on whether ‘Congress has affirmatively and unmistakably instructed that’ the provision at issue should ‘apply to foreign conduct.’” *Id.* The Court concluded that section 1125(a)(1) is not extraterritorial because it does not “provide[] an express statement of extraterritorial application or any other clear indication that it is one of the ‘rare’ provisions that nonetheless applies abroad.” Slip. Op. at 6.

Having concluded that § 1125(a)(1) is not extraterritorial, the Court “move[d] to step two, which resolves whether the suit seeks a (permissible) domestic or (impermissible) foreign application of the provision.” Slip Op. at 4. “To make that determination, courts must start by identifying the focus of congressional concern underlying the provision at issue. The focus of the statute is the object of its solicitude, which can include the conduct it seeks to regulate as well as the parties and interests it seeks to protect or vindicate.” *Id.* (citations and internal quotations omitted). The Court stated that mere identification of the statutory focus is not sufficient. Courts instead must also “ask whether the conduct relevant to that focus occurred in the United States

## PUBLIC VERSION

territory. Thus, to prove that a claim involves a domestic application of a statute, plaintiffs must establish that the conduct relevant to the statute's focus occurred in the United States." *Id.* (citations, internal quotations, and emphasis omitted).

As applied to section 1125(a)(1) and Hetronic's claims of trademark infringement, the Court stated that the conduct relevant to the statute's focus is unauthorized use in domestic commerce of a protected trademark when, among other things, that use is likely to cause confusion. Slip Op. at 9; *see also* Slip Op. at 14–15 ("Under the Act, the term use in commerce means the bona fide use of a mark in the ordinary course of trade, where the mark serves to 'identify and distinguish the mark user's goods and to indicate the source of the goods' (cleaned up)). Thus, per *Abitron*, the relevant use in domestic commerce with respect to a claim of trademark infringement is use of the mark, not a product that may be associated with the mark.

By analogy here, the conduct relevant to the focus of section 1125(a)(1) with respect to a claim of false advertising is the unauthorized use of Vego Garden's photographs to advertise Utopban's raised metal garden bed products. The question *Abitron* directs courts to address is whether that conduct was domestic. If the answer is yes, there is an appropriate non-extraterritorial claim under section 1125(a)(1). If the answer is no, there is not. Slip Op. at 9–10.

There is no dispute that Utopban used Vego Garden's photographs to advertise Utopban's raised metal garden bed products through its website and Instagram account. CX-0071; CX-0073; CX-0075; CX-0076; CX-0078; CX-0079; and SX-0008.001. There is no dispute that Utopban's website and Instagram account with Vego Garden's photographs were available in the United States. Respondents *Abitron* Br. at 3 (EDIS Doc. ID 802113). That availability demonstrates domestic use in commerce by Utopban. *See Abitron*, J. Jackson (concurring), Slip Op. at 4, n.2 ("in the internet age, one could imagine a mark serving its critical source-identifying function in

## PUBLIC VERSION

domestic commerce even absent the domestic physical presence of the items whose source it identifies,” *quoting* 5 J. McCarthy, Trademarks and Unfair Competition § 25.56 (5th ed. Supp. 2023) (“The use of an infringing mark as part of an Internet site available for use in the United States may constitute an infringement of the mark in the United States”)); *Food Processing Equipment*, Inv. No. 337-TA-1161, Initial Determination at 27 (“an article sold and imported in connection with the unauthorized use of a certification mark on a website may represent an unfair act under section 337(a)(1)(A)”), *quoting* *Cardservice Int’l, Inc. v. McGee*, 950 F. Supp 737, 741 (E.D. Va. 1997) (considering domain name use and stating, “[t]he terms of the Lanham Act do not limit themselves in any way which would preclude application of federal trademark law to the internet. Unauthorized use of a domain name which includes a protected trademark to engage in commercial activity over the internet constitutes use ‘in commerce,’ 15 U.S.C. Section 1114(1), of a registered mark.”).<sup>30</sup>

Vego Garden argues that its “false advertising claim relies upon the Commission’s *in rem* jurisdiction over Respondents’ imported goods,” which it contends “renders the *Abitron* decision wholly inapposite to [its] false advertising claims.” Complainant *Abitron* Br. at 2. (EDIS Doc ID 802112). Vego Garden, however, improperly conflates whether there is a valid claim under 15 U.S.C. § 1125(a)(1) with the Commission’s statutory authority to investigate unfair methods of competition and unfair acts in the importation of articles into the United States under 19 U.S.C. § 1337(a)(1)(A). *TianRui*, 661 F.3d at 1334–35. The *in rem* jurisdiction of the Commission does not supplant the requirement, confirmed in *Abitron*, of use in domestic commerce necessary for a claim under 15 U.S.C. § 1125(a)(1). Instead, a false advertisement must enter into interstate

---

<sup>30</sup> The Supreme Court in *Abitron* held that “in commerce” in section 1114(1)(a) has the same meaning as in section 1125(a)(1). Slip Op. at 6–10.



## PUBLIC VERSION

commerce for there to be a justiciable claim under section 1125(a)(1). The Commission has statutory authority to investigate that claim if the additional requirements of section 337 are met, including importation. While, as Vego Garden argues, the focus of a claim under section 337 is unfair methods of competition and unfair acts in the importation of goods, Complainant *Abitron* Resp. Br. at 2 (EDIS Doc. ID 802377), that focus does not eliminate the predicate requirement of the use of a false or misleading statement in an advertisement in domestic commerce for a cognizable false advertising claim under 15 U.S.C. § 1125(a)(1), as confirmed by the Supreme Court in *Abitron*.

In their supplemental briefing addressing *Abitron*, Respondents correctly note that the relevant conduct in a false advertising claim relates to the “false or misleading statement,” but then contend that none of statements made by Utopban “occurred in the United States” because “[a]ll of Utopban’s employees including the marketing team are located outside of the United States, and the marketing and research activities are also located outside of the United States as well.” Respondents *Abitron* Br. at 3; *see also* Respondents *Abitron* Resp. Br. at 3 (contending that there “was no indicator that Utopban’s advertisements on Instagram were generated in the United States or its territories”). The question, however, is not the origin of the false statement. Instead, the question is whether the false statement entered into interstate commerce. Slip Op. at 9–10. It is therefore irrelevant that Utopban initiated the false statements outside the United States. Instead, by Respondents’ own admission, Utopban’s website and Instagram with the false statements (Utopban’s use of Vego Garden’s photographs) were accessible worldwide, including in the United States. Respondents *Abitron* Br. at 3. As a result, per *Abitron*, Vego Garden’s false advertising claim under section 1125(a)(1) is a permitted, non-extraterritorial application of that statute.

## PUBLIC VERSION

In addition to the availability in the United States of Utopban’s website and Instagram account using Vego Garden’s photographs, the evidence demonstrates that Utopban’s advertisements using Vego Garden’s photographs actually entered interstate commerce. Respondents contend that “Complainant failed to provide any evidence demonstrating that the advertising was specifically directed at the United States.” Respondents *Abitron* Resp. Br. at 4. Respondents do not explain what they mean by “specific direction” and nothing in § 1125(a)(1) requires “specific direction.” To the extent required, however, the evidence demonstrates that Utopban specifically advertised its raised garden bed products in the United States using Vego Garden’s photographs.

The only products that Utopban sells are raised metal garden bed products. CX-0501 (Li Dep.) at 20:19–21. In 2022, approximately 90% of Utopban’s revenue was related to importation into the United States of raised metal garden bed products. Tr. (Li) 325:25–326:18. Utopban distributors use Utopban’s website so that “consumers are able to purchase [its] products directly from such link.” CX-0501 (Li Dep.) at 13:8–20. Mr. Li testified that users of Utopban’s Instagram account asked Utopban, “why are we using someone else’s photo to illustrate our own product?” Tr. (Li) at 312:23–313:7. A potential Vego Garden customer, who identified himself as being from Milwaukee, Wisconsin, reported that Utopban’s “pics of products are almost identical to yours.” CX-0002. Given that the vast majority of Utopban’s revenue is from sales into the United States and that (1) Utopban customers can and do use its website to purchase Respondents’ raised garden bed products in the United States and (2) multiple Utopban customers asked through social media why Utopban was using Vego Garden’s photographs to advertise its products, there is no question that Utopban’s false advertising actually entered into interstate commerce.

## PUBLIC VERSION

The record evidence thus demonstrates that Utopban’s false advertisements entered into interstate commerce.

### 5. Vego Garden Was Injured by Utopban’s False Statements

“[T]o succeed on a false advertising claim under the Lanham Act, a plaintiff must show, besides the other elements, that it has been or is likely to be injured as a result of a false or misleading statement of fact.” *Food Processing Equipment*, Inv. No. 337-TA-1161, Initial Determination at 32, citing *Verisign Inc. v. XYZ.com LLC*, 848 F.3d 292, 298–99 (4th Cir. 2017). Similarly, to demonstrate a violation under section 337(a)(1)(A) based on false advertising, a complainant must demonstrate a causal nexus between a respondent’s false advertising and its injury. *Id.* at 17. Whether Vego Garden has demonstrated such causal nexus (and thus whether it has shown “it has been or is likely to be injured as a result of a false or misleading statement of fact”) is addressed in section IX.B.2.b. For the reasons explained there, the evidence supports that Vego Garden was injured by Utopban’s false statements.

## IX. DOMESTIC INDUSTRY

Commission investigations involving trade secret misappropriation and false advertising are governed by 19 U.S.C. § 1337(a)(1)(A), which declares unlawful—

Unfair methods of competition and unfair acts in the importation of articles . . . , into the United States, or in the sale of such articles by the owner, importer, or consignee, the threat or effect of which is—

- (i) to destroy or substantially injure an industry in the United States;
- (ii) to prevent the establishment of such an industry; or
- (iii) to restrain or monopolize trade and commerce in the United States.

19 U.S.C. § 1337(a)(1)(A).

## PUBLIC VERSION

Vego Garden must demonstrate that it has an “industry in the United States” that has suffered “actual substantial injury, or threat of substantial injury.”<sup>31</sup> 19 U.S.C. § 1337(a)(1)(A)(i); *Rubber Resins*, Inv. No. 337-TA-849, Comm’n Op. at 10 (“Therefore, there is a requirement not only that the complainant demonstrate the existence of a domestic industry, but also that there be actual substantial injury or the threat of substantial injury to a domestic industry”); *see also Certain Foodservice Equipment and Components Thereof*, Inv. No. 337-TA-1166, Comm’n Remand Op. at 10 (Dec. 16, 2020) (EDIS Doc. ID 728171) (*Foodservice Equipment*). Whether Vego Garden has demonstrated (1) the existence of a domestic industry; and (2) injury to that domestic industry are addressed in turn below.

### A. Existence of a Domestic Industry

To determine whether an “industry in the United States” exists under section 337(a)(1)(A)(i), the Commission considers the “nature and significance of complainants’ business activities in the United States that relate to complainants’ domestic industry products to determine whether there are sufficient qualifying activities to constitute an industry in the United States.” *Bone Cements*, Inv. No. 337-TA-1153, Comm’n Op. at 22. Where a Complainant’s domestic industry product is manufactured outside the United States, a domestic industry may be established through activities having a close relationship to the domestic industry products. *See Certain Airtight Cast-Iron Stoves*, Inv. No. 337-TA-69, USITC Pub. No. 1126, Comm’n Op. at 11 (Jan. 1981) (EDIS Doc. ID 235399) (*Cast-Iron Stoves*). Further, the domestic industry does not have to involve use of the asserted trade secrets, but the domestic industry must be the industry that is targeted by, or that directly competes with, the unfair imports. *TianRui*, 661 F.3d at 1337.

---

<sup>31</sup> Vego Garden does not allege injury to a domestic industry under section 337(a)(1)(A)(ii) or (iii). *See Complainant Post-Hearing Br.* at 43–46; and *Staff Post-Hearing Br.* at 59–61.

## PUBLIC VERSION

### 1. Investments in and Expenditures on Qualifying Activities

In considering whether a complainant's domestic activities are qualifying, the Commission has highlighted that in using the word "industry," and not "manufacturing," section 1337(a)(1)(A) covers "more than just domestic manufacturing." *Bone Cements*, Inv. No. 337-TA-1153, Comm'n Op. at 24, citing *Schaper Mfg. Co. v. Int'l Trade Comm'n*, 717 F.2d 1368, 1373 (Fed. Cir. 1983) ("in proper cases 'industry' may encompass more than the manufacturing of the [domestic industry] item"). The lodestar in determining what non-manufacturing activities in the United States qualify toward a domestic industry is "whether a complainant's domestic activities are distinguishable from those of a mere importer." *Bone Cements*, Inv. No. 337-TA-1153, Comm'n Op. at 22; *Foodservice Equipment*, Inv. No. 337-TA-1166, Comm'n Op. at 6 (Oct. 29, 2021) (EDIS Doc. ID 755527). There is no "bright-line rule" in making this assessment. *Id.*

Depending on the facts and circumstances of a particular investigation, activities that may qualify include product development, and related engineering, start-up operations, and technical assistance, *Bone Cements*, Inv. No. 337-TA-1153, Comm'n Op. at 22–25, citing *Certain Apparatus for the Continuous Prod. of Copper Rod*, Inv. No. 337-TA-52, USITC Pub. No. 1017, Comm'n Op. at 53–55 (Nov. 1979) (EDIS Doc. ID 217930), as well as education and training and research and development, *id.* at 30 and 34. Other activities may also be considered qualifying, including, in appropriate circumstances, marketing and sales activities when those activities have a relationship with a complainant's "significant investment in manufacturing and servicing products." *Certain Toner Cartridges, Components Thereof, and Systems Containing Same*, Inv. No. 337-TA-1174, Order No. 40 at 114, n.31 (Jul. 23, 2020) (EDIS Doc. ID 716848), *unreviewed* by Comm'n Notice (Sep. 8, 2020) (EDIS Doc. ID 719096). Marketing and sales activities in the United States alone, however, are not sufficient qualifying activities. H.R. Rep. No. 100-40, Pt. 1,

## PUBLIC VERSION

at 157 (1988). Likewise, the Commission often considers activities such as administrative overhead, inspections, and warehousing associated with importation of the domestic industry product as non-qualifying activities of a mere importer. *Bone Cements*, Inv. No. 337-TA-1153, Comm’n Op. at 22. Importantly, qualifying activities must “relate to complainants’ domestic industry products.” *Id.*

After considering what activities qualify as contributing to the domestic industry, the Commission considers the investments or expenditures that have been made in those activities. *Bone Cements*, Inv. No. 337-TA-1153, Comm’n Op. at 26. Those can include investments or expenditures in plant, equipment, land, labor, and capital, among others. *Id.*

### a) **Vego Garden’s Business**

Vego Garden is a start-up company located in Houston, Texas. Its products are modular raised metal garden beds that can be configured in a variety of ways based on customer preference. JX-0010 (identifying Vego Garden products); and Tr. (Xiong) at 198:6–16 (describing the three different heights of each of five different configurations in Vego Garden’s current product line). Mr. Xiong, one of Vego Garden’s founders, testified that he started working on raised metal garden bed products around the beginning of 2020, sold his first product in July 2020, and formally founded Vego Garden at the end of 2020. *Id.* at 25:8–22. He testified that he started the company because he saw an opportunity for a market for raised garden beds in the United States. *Id.* at 25:23–26:14. According to Mr. Xiong, at that time, there were no major brands selling raised metal garden beds in the United States. *Id.* at 26:5–18.

In a relatively short period of time, Vego Garden’s business has grown substantially. Mr. Xiong testified that Vego Garden had over ██████ in revenue in 2021, around ██████ in revenue in 2022, and projected revenue of ██████ for 2023, having booked ██████ in revenue as of mid-May

## PUBLIC VERSION

2023. Complainant Post-Hearing Br. at 41; Tr. (Xiong) at 33:4–34:6; JX-0013C (identifying Vego Garden sales revenue from January through December 2022); CX-0038C (identifying revenue for January and February 2023).<sup>32</sup> Nearly all of Vego Garden’s business in the United States relates to raised metal garden bed products and accessories, accounting for more than 95% of its revenue. Tr. (Xiong) at 27:19–24.<sup>33</sup>

Vego Garden contends that it has a domestic industry through its raised metal garden bed products, which are sold in the United States. Complainant Post-Hearing Br. at 40–43. Because its domestic industry products are manufactured in China, Vego Garden does not rely on domestic manufacturing activity as establishing a domestic industry.<sup>34</sup> Instead, Vego Garden contends that it performs qualifying domestic activities in research and development and testing. *Id.*

---

<sup>32</sup> Respondents contend that Vego Garden provided inconsistent revenue numbers. Respondents Post-Hearing Resp. Br. at 38. At the hearing, Mr. Xiong testified that Vego Garden’s 2022 revenue was [REDACTED]. Tr. (Xiong) at 32:3–8. JX-0013C is a spreadsheet produced by Vego Garden identifying “Sales Amount by Item Summary” and identifies revenue of [REDACTED] for 2022 for the identified raised metal garden products. Mr. Xiong testified that 99% of the products identified on that spreadsheet were sold in the United States, with the remainder being sold in Canada or Europe. Tr. (Xiong) at 174:16–175:7. Taking a conservative estimate, the evidence supports that Vego Garden had approximately [REDACTED] in revenue from the sale of raised metal garden beds in 2022. Respondents also contend that “Complainant’s Demonstrative No. 1” contains a different revenue figure. Respondents Post-Hearing Resp. Br. at 38. That demonstrative, however, was not addressed at the hearing and is not on the exhibit list. *See* Exhibit List (Sept. 5, 2023) (EDIS Doc. ID 803757).

<sup>33</sup> Respondents contend that Vego Garden’s revenue documents are “poorly drafted based on professional accounting standard” and not “in compliance with industry standard and practice.” Respondents Post-Hearing Resp. Br. at 40. Vego Garden’s revenue documents (JX-0013C and CX-0038C), however, look very much like those provided by Green Giant. *See* CX-0500 (Lu Dep.) at 59:2–60:20; JX-0045; and JX-0046.

<sup>34</sup> Respondents contend that because this investigation was instituted under § 337(a)(1)(A), “to prevail Complainant must thus engage in production of the domestic industry products in the United States.” Respondents Post-Hearing Br. at 33. This is wrong. Domestic manufacture of the alleged domestic industry product is not required for a complainant to demonstrate a domestic industry. *See Foodservice Equipment*, Inv. No. 337-TA-1166, Order No. 15 at 10 (Feb. 4, 2020) (EDIS Doc. ID 701355).

**PUBLIC VERSION**

**b) Vego Garden’s Research and Development and Testing Activities**

Vego Garden maintains a 45,000 square foot combined office and warehouse facility in Houston as well as a two-acre farm outside of Houston. Tr. (Xiong) at 35:11–22, 36:12–21; Complainant Post-Hearing Br. at 41. Vego Garden contends that its qualifying domestic industry activities occur at both facilities. Tr. (Xiong) at 41:19–25 (explaining that employees in customer support, marketing and sales, and executive departments are involved in research and development and testing activities related to its domestic industry products work from both its office and warehouse facility and from the farm).

As depicted below, as of the end of 2022, Vego Garden had 47 employees in the United States.<sup>35</sup> Those employees were members of six departments, namely, customer support, sales and marketing, operations, warehouse, accounting, and executive.

<b>Department</b>	<b>Number of Employees</b>	<b>Payroll</b>
Customer Support	16	\$396,000
Sales and Marketing	10	\$443,000
Operations	7	\$256,000
Warehouse	7	\$200,000
Accounting	4	\$115,000
Executive	3	\$518,000

CDX-0003 (above, showing number of employees in each department and payroll totals for 2022); Tr. (Xiong) at 36:22–37:4, 39:9–17, 41:1–18 (identifying departments, employees, and payroll expenses), and 201:19–25 (confirming that above data is for the United States).

---

<sup>35</sup> As of the hearing, Vego Garden had approximately 65 U.S.-based employees. Tr. (Xiong) at 200:25–201:1.



## PUBLIC VERSION

Mr. Xiong testified that U.S. employees in three of Vego Garden's six departments engage in research and development and testing activities, namely in the customer support, sales and marketing, and executive departments. *Id.* at 37:5–22. Mr. Xiong testified that he and his co-founders spent five to six months on research before entering the market, including creating prototypes. *Id.* at 26:19–27:18 and 28:2–6. He also testified that he developed the alleged trade secrets between 2020 and 2021. *Id.* at 29:13–15. Mr. Xiong also explained that the research and development activities of the customer support and marketing departments involve interfacing with customers, collecting feedback and using that feedback so that Vego Garden knows how to improve its products as well as collecting market intelligence about pricing so that Vego Garden knows how to improve and position its product line. *Id.* at 37:23–38:24. He also testified that all three of the customer support, sales and marketing, and executive departments identify opportunities for new products. *Id.* at 38:1–39:2. The evidence also shows that research and development and testing activities took place in the United States with respect to each of Vego Garden's alleged trade secrets. *Id.* at 61:13–62:1 (testing of protective film used on raised garden bed products), 58:13–59:9 (research and development of 8-inch product), and 62:14–64:1 (design of new bending machine by Mr. Xiong).

Further with respect to its domestic research and development and testing activities, Vego Garden contends that it uses the farm it purchased in 2022 to test its prototypes and subject its raised garden bed products to real-life conditions. Complainant Post-Hearing Br. at 41; Tr. (Xiong) at 36:12–21 (use of the farm for testing activities), 109:1–12 (performing product testing on the farm), 206:10–14 (explaining that the farm is where Vego Garden “can put the garden bed into use and see how long it’s going to hold . . . during the normal usage”). Mr. Xiong testified that the farm is also used to create marketing and social media content. Tr. (Xiong) at 36:12–21.

## PUBLIC VERSION

The evidence demonstrates that the research and development and testing activities identified by Vego Garden all relate to its domestic industry products, namely its raised metal garden bed products. *Bone Cements*, Inv. No. 337-TA-1153, Comm’n Op. at 22. Vego Garden’s identified activities, therefore, have a close relationship to its domestic industry products. *Cast-Iron Stoves*, Inv. No. 337-TA-69, Comm’n Op. at 11.

Respondents contend that “Complainant’s claim of farm for products testing and research and development is considered new evidence and theory that was not disclosed in its pre-hearing brief” and was therefore waived. Respondents Post-Hearing Resp. Br. at 5; *see also id.* at 38. This is wrong. When addressing its alleged domestic industry in its pre-hearing brief, Vego Garden stated that it “has also invested in a research and development facility located outside of Houston, Texas, where Vego tests its designs and creates marketing and advertising materials.” Complainant Pre-Hearing Br. at 29; *see also* Staff Post-Hearing Resp. Br. at 14, n.8 and SX-0005C.003 (Vego Garden supplemental response to Staff interrogatory no. 3, identifying “2 acre test facility outside of Houston”). Because Vego Garden timely identified its farm and activity on that farm as part of its alleged domestic industry, this contention was not waived.<sup>36</sup>

Vego Garden does not track the specific amounts of time its employees spend on its research and development and testing-related activities. Mr. Xiong, however, provided a general allocation of time percentages for the relevant departments based on his knowledge of his business. *See* Tr. (Xiong) at 106:18–22 (testifying that Vego Garden has a general idea how much time people are spending on research and development activities). Mr. Xiong estimated that the

---

<sup>36</sup> Respondents also argue that “Complainant’s reliance on activities such as inspections, warehousing of imported products, and sales and marketing is improper.” Respondents Post-Hearing Resp. Br. at 37. Vego Garden, however, is not relying on such activities. *See* Complainant Post-Hearing Br. at 40–43.

## PUBLIC VERSION

customer support and sales and marketing departments each spend approximately 20% of their time on research and development and testing-related activities with respect to Vego Garden's raised metal garden bed products, while the executive department spends from 20-50% of its time on those types of activities. *Id.* at 37:5–22; Complainant Post-Hearing Br. at 41.

Respondents contend that it is unknown how Mr. Xiong “estimated the customer support and sales and marketing department each spend approximately 20% of their time on R&D and testing-related activities while the executive department spends from 20-50% of its time on these activities.” Respondents Post-Hearing Resp. Br. at 40–41. Respondents also argues that Mr. Xiong is not qualified to provide those estimates because he “is not a finance major” and is instead a “mechanical and electrical engineer” meaning that “his calculation and tracking method is questionable given his major probably does not offer any classes regarding finances and economics.” *Id.* at 41; *see also id.* at 42.

Respondents did not challenge Mr. Xiong's estimates or methodology at the hearing. *See* Tr. (Xiong) at 78–208. In addition, as CEO, Mr. Xiong is in a position to know and provide estimates on the amount of time Vego Garden employees spend on certain activities. No special expertise, including a background in finance or economics, is required to do so. In addition, Vego Garden is a small company, and all U.S. employees are located in the same geographic region, sharing space at its office and warehouse facility and/or on the farm. In addition, as a founder of the company and a member of its executive department, Mr. Xiong is in a position to know how much time employees in the U.S. as a whole and members of the executive group specifically spend on research and development and testing activities. Given the facts here, I find that Mr. Xiong's estimates are credible and reasonable.

**PUBLIC VERSION**

Using the time estimates provided by Mr. Xiong and the 2022 employee headcounts in each of the relevant departments (16 employees in customer support, 10 employees in sales and marketing, and 3 executives), the evidence supports that in 2022, Vego Garden’s research and development and testing-related labor expenses were between \$271,400 and \$426,800. Complainant Post-Hearing Br. at 42; Staff Post-Hearing Br. at 55. In 2022, Vego Garden’s total payroll costs for its 47 employees were around \$1.9 million. CDX-0003; and Tr. (Xiong) at 41:9–10. Those amounts are shown in the table below.

<b>Department</b>	<b>Number of Employees</b>	<b>2022 Payroll</b>	<b>Percent R&amp;D and Testing</b>	<b>Attributable Payroll</b>
Customer Support	16	\$396,000	20%	\$79,200
Sales and Marketing	10	\$443,000	20%	\$88,600
Executive	3	\$518,000	20–50%	\$103,600 – \$259,000 <sup>37</sup>
TOTAL		\$1.928M		\$271,400 – \$426,800

With respect to domestic expenditures on space that Vego Garden used to perform its qualifying activities in 2022, Mr. Xiong testified that Vego Garden paid \$240,000 in 2022 to lease its office and warehouse facility and \$694,000 to purchase the two-acre farm. Tr. (Xiong) at 35:17–22.<sup>38</sup> He also testified that in 2022 Vego Garden invested approximately \$94,000 in maintenance

---

<sup>37</sup> This range is consistent with other evidence identifying the salaries of those primarily responsible for research and development of Vego Garden’s raised metal garden bed products. SX-0004C.016 (response to interrogatory no. 24).

<sup>38</sup> Respondents point to what they contend are inconsistencies in the amount Vego Garden spent on the lease for its Houston office and warehouse facility, noting that Vego Garden provided a higher number in discovery for its lease expenses since 2020. Respondents Post-Hearing Resp. Br. at 36. That higher number, however, is not relied upon by Vego Garden.

## PUBLIC VERSION

and other costs relating to the farm. Tr. (Xiong) at 35:23–36:5.<sup>39</sup> As noted by the Staff, the headcounts and percentages Vego Garden uses to allocate payroll expenses to research and development and testing-related activities could also be used to allocate the 2022 rental expense of its Houston office and warehouse facility. Staff Post-Hearing Br. at 55, n.23. Respondents appear to agree. Respondents Post-Hearing Resp. Br. at 35 (lease expenses should be allocated to qualifying domestic industry activities). Doing so, the Staff estimates that 17% of Vego Garden’s U.S. employees in 2022 engaged in research and development and testing activities and applying that percentage to the \$240,000 in 2022 lease expenses yields \$40,800 attributable to research and development and testing lease expenses. I agree that Vego Garden’s lease expenses should be allocated to include only those relating to its qualifying research and development and testing activities (and to thus exclude expenses relating to, among other things, warehousing products before sale).<sup>40</sup> I also agree with the estimate identified by the Staff.

Respondents challenge the allocation of qualifying salary and property expenditures because Vego Garden “shares the same employees with another company Worldlink, and Worldlink sells other products on Amazon.” Respondents Post-Hearing Resp. Br. at 39; *see also id.* at 36 and 37. Mr. Xiong testified, however, that Worldlink is the predecessor company to what is now known as Vego Garden. Tr. (Xiong) at 25:12–22 (Worldlink made the first sales of raised metal garden bed products before Vego Garden was formally founded), at 94:7–95:12 (Worldlink

---

<sup>39</sup> Mr. Xiong also testified that Vego Garden plans to expand the farm by three acres, which it will purchase for \$600,000. Tr. (Xiong) at 36:6–11.

<sup>40</sup> Respondents point to other expenditures identified by Vego Garden in discovery (“services, including shipping,” “Warehouse fixtures and equipment,” and “Office equipment”), asserting those expenditures are “nothing different from being an importer.” Respondents Post-Hearing Resp. Br. at 36. Vego Garden, however, does not rely on those expenditures in arguing that it has a domestic industry. Complainant Post-Hearing Br. at 40–43.

**PUBLIC VERSION**

made the early sales of raised metal garden bed products before all its employees became employees of Vego Garden), and at 95:18–22 (“[Worldlink is] the same group of people. And it is correct to say that Worldlink is part of Vego Garden.”). Mr. Xiong also testified that Vego Garden’s Amazon store sells a Worldlink body fat scale, Tr. (Xiong) at 163:22–164:19, but the revenue information Vego Garden provided identifies revenue for only Vego Garden’s raised metal garden bed products. *See, e.g., JX-0013C, CX-0038C.* In addition, the evidence shows that the research and development and testing activities that Vego Garden performs with respect to its raised metal garden bed products are unique to those products and do not apply to any body fat scales of Worldlink. I therefore find that the research and development and testing activities identified with respect to Vego Garden’s raised garden bed products apply only to those products as do the qualifying expenditures relating to those activities.

Based on the purpose and work done at Vego Garden’s farm, I agree with the Staff that it is appropriate to allocate the entirety of the 2022 farm purchase (\$694,000) and related expenses (\$94,000) to Vego Garden’s research and development and testing-related investments in its domestic industry products. Staff Post-Hearing Br. at 55–56, n.23.

The evidence thus supports the following property-related expenses in 2022 of Vego Garden with respect to its research and development and testing activities:

<b>Expense</b>	<b>2022 Amount</b>	<b>Percent Attributable</b>	<b>Attributable Amount</b>
Lease (office/warehouse)	\$294,000	17%	\$40,800
Farm purchase	\$694,000	100%	\$694,000
Farm costs	\$94,000	100%	\$94,000
<b>TOTAL</b>			<b>\$828,800</b>

## PUBLIC VERSION

Vego Garden contends that in 2022, it also incurred “non-real-estate, non-payroll R&D expenses” relating to new product research and development of approximately \$467,000. Complainant Post-Hearing Br. at 42; Tr. (Xiong) at 42:4–9. While Mr. Xiong characterized those expenses as relating to new product research and development, it is not clear what activities are included in these expenses. There is evidence, however, that at least some of these expenses are related to Vego Garden’s engagement of a lab at Texas A&M University (in College Station, Texas) to test the corrosion resistance of the metal materials in its raised garden bed products. Tr. (Xiong) at 205:19–206:9; SX-0004C.008; and SX-0022C. There is also evidence that Vego Garden invests in additional outside research by providing its products to gardeners to have them test its raised metal garden beds under real-world conditions and provide feedback. Tr. (Xiong) at 206:6–9 (characterizing this as “real life research”). Because Vego Garden did not provide details about its \$467,000 investment in research and development and testing expenses in 2022 but recognizing that Vego Garden provided evidence of exemplary ones of such expenses, the Staff proposed reducing by half the amount of the expenses Vego Garden identified. Staff Post-Hearing Br. at 57, n.25 and n.26. Given the substantial nature of the activities specifically identified by Vego Garden, I agree with the Staff’s estimate.

Based on the evidence, I conclude that in 2022, Vego Garden expended between \$1,333,700–\$1,489,100 in expenses related to payroll, property and expenses for research and development and testing activities in the United States relating to its domestic industry products. This is shown in the table below:

**PUBLIC VERSION**

Item	Amount
Payroll	\$271,400–\$426,800
Property	\$828,800
Expenses	\$233,500
TOTAL	\$1,333,700– \$1,489,100 <sup>41</sup>

Respondents do not contest that Vego Garden undertakes research and development and testing activities in the United States relating to its raised metal garden bed products, instead arguing that there “was no evidence presented at the Hearing that would corroborate Complainant’s testimony” and that “the numbers that Complainant asserted in its pre-hearing brief and at the Hearing” “are mere speculation without any evidence to corroborate.” Respondents Post-Hearing Br. at 1 and 32.<sup>42</sup> The testimony that Mr. Xiong provided, however, is evidence. Further, “there is no Commission requirement that sworn witness testimony directed to the domestic industry requirement cannot be credited without further corroboration by underlying documentation. Instead, all that is required is the use of reasonable allocations for the purposes of establishing the economic prong of the domestic industry requirement.” *Certain Solid State*

---

<sup>41</sup> As noted, Respondents challenge the accuracy of the numbers provided by Vego Garden. *See* Respondents Post-Hearing Resp. Br. at 33–42; *see also* Respondents Post-Hearing Br. at 32. Respondents contend that Vego Garden’s figures are “problematic” and analogize them to those addressed by the Commission in *Certain Airless Paint Spray Pumps and Components Thereof*, Inv. No. 337-TA-90. Respondents Post-Hearing Resp. Br. at 38–39. There, the Commission noted that accounting figures are “singularly subject to manipulation, particularly in a default case.” USITC Pub. No. 1199 (Nov. 1981) Comm’n Op. at 14 (EDIS Doc. ID 267011). In a default situation, the issue identified by the Commission is more acute because there is no opposing party to challenge information provided by the complainant. That was not the situation here. Respondents were available to challenge the numerical evidence provided by Vego Garden at the hearing, but by and large they did not. *See* Tr. (Xiong) at 78–208.

<sup>42</sup> Respondents point to RX-0082C when contesting the information Vego Garden provided on its research and development costs. That item, however, is not an exhibit. *See* Respondents’ Exhibit List (Sept. 6, 2023) (EDIS Doc. ID 803915).



**PUBLIC VERSION**

*Storage Devices, Stacked Electronic Components, and Products Containing Same*, Inv. No. 337-TA-1097, Comm'n Op. at 21–22 (Jun. 29, 2018) (citations omitted) (EDIS Doc. ID 649139).

I agree with the Staff that Respondents have not offered any persuasive evidence or argument demonstrating that Mr. Xiong's testimony was not credible. Staff Post-Hearing Resp. Br. at 15. In addition, given the status of Vego Garden as a relatively new and small company, the evidence provided by Vego Garden regarding its domestic expenditures was reasonable and reliable. Further, the allocations provided by Vego Garden are reasonable. Vego Garden's estimates of the number of its U.S. employees that spend time on research and development and testing activities are reasonable given its overall workforce as are the estimates of the amounts of time those employees spend on those activities relative to their overall time.

Respondents also contend that "investments in design cannot support the existence of a domestic industry under § 1337(a)(1)(A)." Respondents Post-Hearing Br. at 32, *citing Schaper*, 717 F.2d at 1373. In *Schaper*, as here, the domestic industry products were manufactured outside the United States. That, however, did not end the inquiry. The design activities relied on for the alleged domestic industry in *Schaper* were "general" and not related to the asserted patent. 717 F.2d at 1371, n.7. In addition, the Federal Circuit concluded that the complainant had not shown any significant activities in the United States beyond those of a mere importer. *Id.* at 1372–73. In doing so, the court noted that the complainant had not shown that its research and development activities were connected to the alleged domestic industry product. *Id.* at 1371, n.7.

In contrast, the evidence supports that the research and development and testing activities performed by Vego Garden in the United States are not those of a mere importer and involve product design and development and testing directly connected to the domestic industry products. Respondents contend that Vego Garden fails to distinguish itself from a mere importer because it

## PUBLIC VERSION

“failed [to] present evidence regarding the activities of a U.S. importer in the relevant industry.” Respondents Post-Hearing Resp. Br. at 37. I disagree. A mere importer would not perform research on and design the domestic industry products. A mere importer would not have a farm at which it tested the domestic industry products and developed new domestic industry products. A mere importer would not work with an outside lab to test its products. A mere importer would not work with users to test products and receive input about its products to improve and develop new products. The evidence thus demonstrates that Vego Garden’s non-manufacturing activities within the United States are well beyond those of a mere importer. I therefore conclude that Vego Garden has demonstrated qualifying domestic industry expenditures in research and development and testing-related activities.

### **2. Significance of Investments in and Expenditures on Qualifying Activities**

Having determined the investments and expenditures made with respect to qualifying activities, the Commission determines whether they are “sufficient to constitute a domestic industry.” *Bone Cements*, Inv. No. 337-TA-1153, Comm’n Op. at 22. The existence of a domestic industry is “not based on the amount of the investment divorced from the circumstances of a particular case.” *Certain Beverage Dispensing Systems and Components Thereof*, Inv. No. 337-TA-1130, USITC Pub. No. 5083 (Jun. 2020), Comm’n Op. at 18 (EDIS Doc. ID 706256). Instead, the significance or substantiality of domestic industry expenses are evaluated “based on a proper contextual analysis in the relevant timeframe such as in the context of the complainant’s or its licensee’s operations, the marketplace, or the industry in question.” *Id.* (internal quotations omitted).

## PUBLIC VERSION

In doing so, the Commission has looked to “several different contextual indicators,” including, in appropriate circumstances, “comparing complainant’s domestic expenditures to its foreign expenditures” or considering “the value added to the article in the United States by the domestic activities.” *Bone Cements*, Inv. No. 337-TA-1153, Comm’n Op. at 22. Respondents contend that Vego Garden cannot show that its domestic industry is significant because it “failed to provide any testimony [or] evidence as to how it adds value to the U.S. domestic industry.” Respondents Post-Hearing Resp. Br. at 41. While demonstrating the value added in the United States to a product manufactured abroad is a common way to demonstrate domestic industry, it is not required. *Certain Dynamic Random Access Memories, Components Thereof and Products Containing Same*, Inv. No. 337-TA-242, USITC Pub. No. 2034 (Nov. 1987), Comm’n Op. at 67–68 (EDIS Doc. ID 217491). Other contextual indicators may be appropriate given that determining the nature and significance of a complainant’s domestic activities is highly fact specific and can depend on the nature of the specific industry. *Bone Cements*, Inv. No. 337-TA-1153, Comm’n Op. at 27.

While its domestic industry products are manufactured in China, Vego Garden argues that its domestic research and development and testing-related investments are a significant portion of its overall expenses. Complainant Post-Hearing Br. at 42–43. The Staff agrees. Staff Post-Hearing Br. at 57–58. Vego Garden contends that its total 2022 expenses were approximately \$7.3M. Complainant Post-Hearing Br. at 43; and Tr. (Xiong) at 42:1–3. Using the range of qualifying expenses of \$1,333,700–\$1,489,100, Vego Garden’s 2022 qualifying research and development and testing expenses are between 18.2 and 20.0% of its total expenses. The domestic industry products (and the accused products) are relatively simple – raised metal garden beds – constructed of metal panels that are bolted together. They are mechanical and have few constituent

## PUBLIC VERSION

components. I find that the marketplace for these products does not, and due to price points cannot, require intense research and development costs. As a result, the benchmark for “substantial” research and development investment is relatively low. *Certain Mobile Device Holders and Components Thereof*, Inv. No. 337-TA-1028, USITC Pub. No. 4959, Initial Determination at 79 (Sept. 2019), *aff’d in relevant part*, Comm’n Op. at 19 (EDIS Doc. ID 695068). In that context, Vego Garden’s range of qualifying expenses is quantitatively significant.<sup>43</sup>

Other contextual comparisons support the quantitative significance of Vego Garden’s qualifying expenditures. For example, Mr. Xiong testified that Vego Garden has an office and employees in Shenzhen, China.<sup>44</sup> Tr. (Xiong) at 97:1–98:11. In 2022, Vego Garden employed around 10 people in that office and currently employs around 35 people there. *Id.* at 98:8–11 and 200:21–24. The number of U.S.-based employees in 2022 and at the time of the hearing were 47 and 65, respectively. *Id.* at 98:10–11 and 200:25–201:1. In addition to having larger staff in the United States, Vego Garden’s domestic research and development and testing payroll expenses in 2022 of \$272,400–\$426,800 was close to and likely greater than its entire payroll in China in 2022, supporting the quantitative significance of those expenditures. *Id.* at 202:1–9 (testifying that in

---

<sup>43</sup> In other investigations, overall revenue has been compared with qualifying expenditures. *Foodservice Equipment*, Inv. No. 337-TA-1166, Comm’n Op. at 13. Using that as a basis of comparison, Vego Garden’s qualifying expenses are between [REDACTED] of its overall revenue. Complainant Post-Hearing Br. at 41; Tr. (Xiong) at 33:4–34:6; JX-0013C (identifying Vego Garden sales revenue from January through December 2022 of approximately [REDACTED]). Given the simplicity of the products and the low benchmark for substantial research and development and testing costs, the comparison also supports that Vego Garden’s qualifying expenses were quantitatively significant.

<sup>44</sup> See Order No. 26 (EDIS Doc. ID 797938) granting Motion No. 1334-028 to correct errors in the hearing transcript, including changing “Shunchuen” to “Shenzhen” at Tr. (Xiong) at 97:2 and at 97:5.

## PUBLIC VERSION

2022 Vego Garden’s total payroll expenses for its China-based employees was between \$200,000 and \$300,000).

The evidence also shows that Utopban’s revenue for 2022 was approximately 8.1 million RMB, of which 90% was related to Green Giant’s raised metal garden bed products imported into the United States. Tr. (Li) at 325:25–326:18; *see also* CX-0081C.<sup>45</sup> Vego Garden’s qualifying domestic industry expenses, therefore, are greater than Utopban’s entire 2022 revenue as well as its 2022 revenue in the United States. Vego Garden’s qualifying range of expenditures of \$1,333,700–\$1,489,100 for 2022 is also greater than the “extraterritorial R&D expenses of \$387,000 related to the film and machine trade secrets.” Complainant Post-Hearing Br. at 42, *citing* Tr. (Xiong) at 30:23–31:17 (discussing percentages of indirect development costs paid to Vego Garden’s manufacturer in China). These comparators also support the quantitative significance of Vego Garden’s qualifying expenditures.

As to the qualitative nature of Vego Garden’s qualifying expenditures, Mr. Xiong testified that Vego Garden’s expenditures were necessary to get his new business started and remain necessary to support ongoing product development and maintenance, supporting that the expenses were qualitatively significant. Tr. (Xiong) at 26:19–39:17; 41:19–42:9; 47:23–48:8; and 100:7–19. In addition, the evidence supports that the expenses are directly tied to the domestic industry products, that Vego Garden’s domestic industry products are at least partially designed, developed, and tested in the United States, and that U.S.-based Vego Garden employees are engaged in research and development and testing of the actual domestic industry products, including soliciting

---

<sup>45</sup> Using an average exchange rate for 2022 of 1RMB = 0.1484USD, available from the Wall Street Journal, revenue of Utopban in 2022 for U.S. sales of raised garden bed products was \$1,081,836.

## PUBLIC VERSION

technical customer feedback from U.S. customers to improve Vego Garden's line of domestic industry products and develop new products for the U.S. market.

In addition, while Vego Garden did not create the market in the United States for raised garden bed products, the evidence supports that Vego Garden outsells its competitors in the United States. For example, Birdies is a manufacturer of raised garden beds based in Australia, which distributes raised garden bed products in the United States. According to Mr. Xiong, Birdies has around 25–33% of Vego Garden's U.S. revenue. Tr. (Xiong) at 42:16–23. Another competitor, Olle Garden, has about 10% of Vego Garden's U.S. revenue.<sup>46</sup> *Id.* at 42:24–43:5. Mr. Xiong testified that Green Giant, which entered the U.S. raised garden market after Vego Garden, has U.S. revenue of about 30% those of Vego Garden. *Id.* at 43:6–23. As a result, the evidence supports that although it is a relatively young company, Vego Garden's revenue is greater than its competitors, individually and collectively. That success can, at least in part, be attributed to Vego Garden's domestic expenditures on research and development and testing. Viewing Vego Garden's U.S. expenditures in the context of the raised garden bed market in the United States as a whole supports that its expenditures are qualitatively significant. Vego Garden has the largest revenues of any of its competitors and while at least Birdies may distribute its products in the United States (and thus expend at least some revenue to do so), there is no evidence that any of Vego Garden's competitors have established businesses in the United States or perform research and development or testing activities in the United States. This supports that Vego Garden's expenditures are qualitatively significant.

---

<sup>46</sup> Respondents contend that they have “not engaged in significant business activities in the United States since there are much more competitors in the market that directly compete with Complainants.” Respondents Post-Hearing Br. at 38. Respondents, however, provided no specific evidence on the raised metal garden bed market in the United States.

## PUBLIC VERSION

I find that Vego Garden’s investments in research and development and testing-related activities and facilities are both quantitatively and qualitatively significant. I therefore conclude that Vego Garden has satisfied the domestic industry requirement under 19 U.S.C. § 1337(a)(1)(A)(i).

### **B. Injury to the Domestic Industry**

A complainant alleging unfair methods of competition or unfair acts under 19 U.S.C. § 1337(a)(1)(A)(i) must demonstrate substantial injury or the threat of substantial injury to an industry in the United States.<sup>47</sup> Such injury must be shown by a preponderance of the evidence. *Fischer & Porter Co., Inc. v. Int’l Trade Comm’n*, 831 F.2d 1574, 1581 (Fed. Cir. 1987). The statutory language requires “‘a link’ between the alleged injury and the domestic industry.” *Foodservice Equipment*, Inv. No. 337-TA-1166, Comm’n Remand Op. at 13. That is, the injury must be *to* the domestic industry. Separately, a complainant is required to show “a causal nexus between the unfair acts of the respondents and the injury.” *Id.* at 13, n.10, *citing Rubber Resins*, Inv. No. 337-TA-849, Comm’n Op. at 60–61. Whether there is a substantial injury to Vego Garden’s domestic industry is addressed first, followed by whether there is a causal nexus between the alleged unfair acts of Respondents, namely trade secret misappropriation and false advertising, and the injury to Vego Garden.

#### **1. Vego Garden Has Demonstrated Substantial Injury to Its Domestic Industry**

Substantial injury may be established through a broad range of indicia, such as “the volume of imports and their degree of penetration, complainant’s lost sales, underselling by respondents,

---

<sup>47</sup> Vego Garden does not allege injury under §§ 1337(a)(1)(A)(ii) or (iii). *See* Complainant Post-Hearing Br. at 43, alleging injury only under section 337(a)(1)(A)(i).

## PUBLIC VERSION

reductions in complainants' [] production, profitability and sales, and harm to complainant's good will or reputation that have adverse effects on the domestic industry established in the investigation." *Foodservice Equipment*, Inv. No. 337-TA-1166, Comm'n Remand Op. at 16 (internal citations and quotations omitted); *see also Woven Textile Fabrics*, Inv. No. 337-TA-976, Initial Determination at 9.

The Commission does not require direct evidence of substantial harm to the complainant's domestic activities and investments. *Foodservice Equipment*, Inv. No. 337-TA-1166, Comm'n Remand Op. at 13. Thus, while a complainant can "present direct evidence of substantial harm or threat to their qualifying domestic activities and investments, such as curtailment or abandonment of activities in the presence of a respondent's unfair imports, a complainant can also present circumstantial evidence from which such substantial injury or threat to these activities and investments can be inferred." *Id.* at 14. "Depending on the facts of a case, it may be appropriate to use proof of lost sales and diminished profits to show that a domestic industry has been injured or threatened with injury even where a domestic industry was found based on non-manufacturing activities, because the evidence supports an inference that such lost sales and profits have had or will have the effect of substantially harming or threatening the domestic injury that was found to exist based on its qualifying U.S. activities and investments." *Id.*, citing *Akzo N.V. v. Int'l Trade Comm'n*, 808 F.2d 1471, 1487-88 (Fed. Cir. 1986) (considering respondent's intent and capacity to enter the U.S. market, complainant's resulting loss of revenue and a probable price reduction, diminished profits, lower return on investments, and reduced sales upon entry of respondent's products into the United States as indicative of threat of injury to the domestic industry, where the industry made substantial upfront investments in research and development and expected to recoup those investments through sales of its products); *Corning Glass Works v. Int'l Trade Comm'n*,



## PUBLIC VERSION

799 F.2d 1559, 1569 (Fed. Cir. 1986) (acknowledging that lost sales can “retard [the complainant’s] growth” and its “recoupment of research and development costs” to show substantial injury to a domestic industry when supported by record evidence that respondent’s sales are more than de minimis and there is a nexus between respondent’s sales and the injury).

As an initial matter, Respondents contend that there was no injury to Vego Garden because Vego Garden “could not meet the market.” Respondents Post-Hearing Br. at 34. As support, Respondents state that the Mr. Xiong contacted Mr. Xie, one of the founders of Green Giant, to discuss Green Giant’s manufacturing capabilities. *Id.*; and CX-0037. Respondents infer from this discussion that Vego Garden could not satisfy market demand and thus was not harmed by Respondents’ entry into the market.

Mr. Xiong testified that he contacted Mr. Xie at the request of Mr. Yu of Shun Chuen because Mr. Yu wanted Mr. Xiong to “give some business to Mr. Xie.” Tr. (Xiong) at 52:20–23. During the call, Mr. Xiong stated that Vego Garden needed help with “15 to 16 containers.” CX-0037 at No. 42. While the evidence supports that Mr. Xiong may have been interested in finding another supplier for raised metal garden bed products, the evidence supports that in calling Mr. Xie, Mr. Xiong was interested in finding out if Vego Garden’s confidential information had been taken. Tr. (Xiong) at 53:7–12; *see also* CX-0037. At the hearing, Mr. Xiong testified that Vego Garden has “the manufacturing and sales capacity to supply the entire U.S. market for metal raised garden beds.” Tr. (Xiong) at 48:18–21. The evidence thus does not support that there was no injury to Vego Garden because it “could not meet the market.”

Vego Garden maintains that Respondents’ misappropriation and unfair acts in the importation of the accused raised metal garden beds have “substantially and irreparably injured and threatens [its] domestic industry.” Complainant Post-Hearing Br. at 43. Vego Garden

## PUBLIC VERSION

specifically contends that the evidence demonstrates substantial injury or threat of injury to its domestic industry by way of: (1) price erosion; (2) lost sales and lost revenue; and (3) lost market position and damage to reputation. Complainant Post-Hearing Br. at 43–46. Each is discussed in turn.

### a) Price Erosion

The evidence demonstrates that Respondents were able to enter the raised metal garden bed market quickly and offer their products at lower prices than Vego Garden. Tr. (Xiong) at 44:4–16; *id.* at 45:23–46:5 (testifying that Respondents’ products are sold at prices from 10–40% lower than those of Vego Garden); CX-0501 (Li Dep.) at 32:1–2 (Respondents’ raised metal garden bed products are priced below Vego Garden’s prices); CX-0075 – CX-0078 (Utopban/Vegega product webpages showing discounted prices); CX-0003 (customer asking Vego Garden to match Vegega’s lower price). Mr. Xiong testified that as a result, Vego Garden was forced to cut the prices of its own products “in order to compete against [Respondents].” Tr. (Xiong) at 44:21–45:1; *see also id.* at 45:18–22 (“Because they enter[ed] into the market [at] a lower cost. So we had [to] lower our price in order to compete against them.”). The evidence supports that Respondents’ entry into the market and lower prices forced Vego Garden to reduce its prices, thus injuring Vego Garden.

### b) Lost Sales and Revenue

Vego Garden contends that it lost sales and revenue to Respondents. Complainant Post-Hearing Br. at 43–44. To consider whether lost sales and revenue are attributable to Respondents, the entirety of the market should be considered. *Crawler Cranes*, Inv. No. 337-TA-887, Initial Determination at 4; *Certain Indus. Automation Sys. & Components Thereof*, Inv. No. 337-TA-

**PUBLIC VERSION**

1074, Initial Determination at 58-60 (Oct. 23, 2018) (EDIS Doc. ID 661890), *unreviewed by*, Comm'n Notice (Dec. 20, 2018) (EDIS Doc. ID 664823).

Mr. Xiong testified that Vego Garden's competitors, other than Respondents, are Birdies and Olle Gardens, with revenues of approximately between 25–33% and 10%, respectively, of Vego Garden's revenues. Tr. (Xiong) at 42:10–43:5; and Complainant Post-Hearing Br. at 43. The evidence supports that Birdies and Olle Gardens have been in the raised metal garden bed industry longer than Vego Garden. Tr. (Lu) at 359:7–361:9; *see also* RX-0015; and RX-0017. Upon entry into the United States market after Vego Garden, Vego Garden contends that revenues from Respondents' products became around 30% of Vego Garden's revenue. Tr. (Xiong) at 43:15–23 and 45:5–8.

Respondents contend that Mr. Xiong's estimate of their revenue "is pure speculation" and that "there are no evidence presented at the Hearing to support such claim nor was any evidence produced during fact discovery." Respondents Post-Hearing Resp. Br. at 45. As a founder and the CEO of Vego Garden, however, Mr. Xiong is in a position to know or estimate the revenue of Vego Garden's competitors. In addition, to the extent Respondents wanted to contest Mr. Xiong's estimate of their revenue, they have this information.

Based on the market participants' positions in the market, Vego Garden contends that when Respondents entered the market, they (Respondents) captured around [REDACTED] in revenue in 2022. Based on the Respondents' position in the market, Vego Garden contends that it lost [REDACTED] of that revenue to Respondents in 2022. Complainant Post-Hearing Br. at 43–44. The Staff agrees with these estimates. Staff Post-Hearing Br. at 60–61.

Other record evidence supports lost revenue to Vego Garden from Respondents' sales. Tr. (Li) at 325:25–326:18; CX-0081C; and JX-0044 (Utopban); CX-0500 (Lu Dep.) at 59:2–60:20;

## PUBLIC VERSION

JX-0045; and JX-0046 (Green Giant). Specifically, Mr. Li testified that Utopban placed its first order with Green Giant for raised metal garden bed products in the first quarter of 2022. CX-0501 (Li Dep.) at 77:17–25. The sales information provided by Green Giant shows a first order by Utopban (Vegega) in May 2022. JX-0046. Information provided by Utopban indicates that its revenue for 2022 was approximately 8.1 million RMB, of which 90% was related to importation of raised metal garden bed products into the United States. Tr. (Li) at 325:25–326:18; and CX-0081C. Using an average exchange rate for 2022 of 1RMB = 0.1484USD, available from the Wall Street Journal, Utopban’s revenue in 2022, starting in May, for its U.S. sales of raised metal garden bed products was \$1,081,836. CX-0081C.

Aggregate revenue numbers for Green Giant for its sales to Utopban do not appear to be in the record. *See* JX-0044; JX-0045; and JX-0046. Green Giant indicated, however, that the only company it has directly imported to is Utopban and that it does not track U.S. sales to any entity other than Utopban. SX-0033.011–12. In its response to the Amended Complaint, Green Giant stated that the value of its accused products imported into the United States from January to October 2022 was approximately 73.8 million RMB. Ex. A to Green Giant Response to Amended Complaint, ¶ a. Based on Green Giant’s statement that it only tracks U.S. exports to Utopban, the record supports that the entirety of the value of imported products reported by Green Giant is attributable to Utopban. Using an average exchange rate for 2022 of 1RMB = 0.1484USD, available from the Wall Street Journal, the value of Green Giant’s imported raised metal garden bed products sold to Utopban was close to \$11 million. Based on the Utopban revenue information and the information regarding the value of the Green Giant products sold to Utopban for importation, I find that Mr. Xiong’s estimate that Respondents’ revenues are about 30% of Vego Garden’s revenues is reasonable and credible.

## PUBLIC VERSION

Mr. Xiong also testified that Vego Garden’s revenue growth has been slowed by Respondents’ entry into the market, but that Vego Garden is able to fully supply the U.S. market, Tr. (Xiong) at 45:2–8 and 48:18–21, supporting that at least some of Respondents’ revenue was revenue lost by Vego Garden. Additionally, the evidence supports that once a customer has purchased a raised metal garden bed from one source, they are unlikely to purchase a differently-branded raised metal garden bed or accessories, supporting that additional lost revenue is likely to occur once a customer has selected a brand. *Id.* at 47:8–22; *see also* CX-0501 (Li Dep.) at 67:5–18 (Utopban witness confirming that customers are unlikely to change brands).

Vego Garden also provided evidence of customer confusion caused by Utopban’s use of Vego Garden’s photographs to advertise its products, supporting that Vego Garden lost sales to Respondents as a result of customers believing that Utopban products were Vego Garden products. *See* Tr. (Xiong) at 44:2–16, 55:6–57:12; CX-0001; CX-0002; CX-0003; and Tr. (Li) at 325:3–20 (Utopban general manager confirming that he was aware of at least a “handful of occasions” of customer confusion). This evidence of confusion supports that Vego Garden lost sales to Respondents.

Mr. Xiong testified that Vego Garden had over █████ in revenue in 2021, around █████ in revenue in 2022, and projected revenue of █████ for 2023, having booked █████ in revenue as of mid-May 2023. Complainant Post-Hearing Br. at 41; Tr. (Xiong) at 33:4–34:6; JX-0013C (identifying Vego Garden sales revenue from January through December 2022); CX-0038C (identifying revenue for January and February 2023). The Staff contends that because of its increase in revenue, Vego Garden has not shown a substantial injury to its domestic industry as a result of lost sales and revenue. Staff Post-Hearing Br. at 61. The fact that Vego Garden’s revenues

## PUBLIC VERSION

did not decrease, however, is not dispositive. *See Corning*, 799 F.2d at 1569 (acknowledging that lost sales can retard growth).

Given the small size of the market (*i.e.*, the small number of market participants), the relatively small size of the other and older market participants, Birdies and Olle Garden, the speed with which Respondents have become a substantial player in the market, and the evidence of confusion between Vego Garden's and Respondents' raised metal garden bed products, notwithstanding that Vego Garden's revenues have increased, I find that the evidence supports a substantial injury to Vego Garden in the form of lost sales and revenue.

### **c) Brand Harm**

Before Respondents' entry into the U.S. market, Mr. Xiong testified that Vego Garden was positioning itself as a medium-to-high-end brand. Tr. (Xiong) at 44:17–20. But because Vego Garden needed to lower its prices to compete with Respondents' lower-priced raised metal garden bed products, Vego Garden argues that its market position has been injured. Complainant Post-Hearing Br. at 44 (arguing that this “necessary price-cutting [in] response to Respondents' unfair competition” has damaged Vego's market position). Vego Garden likewise argues that Respondents' unfair competition has damaged Vego Garden's reputation and brand-power among consumers. Complainant Post-Hearing Br. at 44–45. Mr. Xiong also testified that Vego Garden lost out on investment opportunities from private equity companies because of Respondents' entry into the market. Tr. (Xiong) at 46:6–47:7 (testifying that Vego Garden's credibility, in terms of ability to be profitable in the market, was lost as a result of Respondents' unfair competition). The evidence thus supports that Vego Garden's brand was harmed by Respondents' entry into the market.

## PUBLIC VERSION

### d) Conclusion

The evidence demonstrates that Vego Garden has suffered price erosion, lost sales and revenue, and lost market position/brand power. That harm to Vego Garden is to its only business—raised metal garden bed products. As such, that harm is directly linked to Vego Garden’s domestic industry, as required by 19 U.S.C. § 1337(a)(1)(A).

### 2. There Is a Causal Nexus Between Respondents’ Unfair Acts and the Substantial Injury to Vego Garden

“When the complainant alleges actual injury, there must be a causal nexus between the unfair acts of the respondents and the injury.” *Rubber Resins*, Inv. No. 337-TA-849, Comm’n Op. at 61. The complainant must “carry its burden of proving that the respondents’ activities are causally related to any ‘substantial injury’ to the domestic industry.” *Certain Drill Point Screws for Drywall Construction*, Inv. No. 337-TA-116, USITC Pub. No. 1365, Comm’n Op. at 20–22 (Mar. 3, 1983) (EDIS Doc. ID 217888).

### a) There Is a Causal Nexus Between Green Giant’s Trade Secret Misappropriation and Vego Garden’s Injury

Vego Garden must demonstrate a causal nexus between Respondents’ unfair acts in the importation of raised garden bed products using Vego Garden’s misappropriated trade secrets and the injury to its domestic industry. *See Rubber Resins*, Inv. No. 337-TA-849, Comm’n Op. at 61.

There is substantial evidence of a causal nexus between Respondents’ trade secret misappropriation and the injury to Vego Garden’s domestic industry. Respondents’ raised metal garden bed products, which exist solely due to Green Giant’s misappropriation of Vego Garden’s trade secrets, compete directly with Vego Garden’s raised metal garden bed products. Tr. (Xiong) at 42:10–14 (identifying Vegega as a competitor to Vego Garden); Tr. (Xiong) at 43:6–14 (identifying Green Giant customers as competitors in the United States); CX-0501 (Li Dep.) at

**PUBLIC VERSION**

35:22–25 (identifying Vego Gardens as selling the same products as Utopban). In *TianRui*, the Federal Circuit agreed that such direct “type of competition . . . is sufficiently related to the investigation to constitute an injury to an ‘industry’ within the meaning of section 337(a)(1)(A).” 661 F.3d at 1337. The evidence demonstrates that Respondents were only able to get in the market because of the trade secret information acquired by Mr. Lu and provided by Mr. Yu. Indeed, Mr. Yu was introduced to Green Giant because it had “some technical difficulties that [it] could not overcome.” CX-0037 at No. 141. When Green Giant wanted to start a competing raised metal garden bed business, the equipment needed to successfully make the product could not be found. *Id.* at No. 67. Green Giant turned to Mr. Yu, who gave Green Giant the information it needed so that Green Giant’s products were made “in reference to his standards.” *Id.* at No. 81. Mr. Xie, a co-founder of Green Giant admitted to Mr. Xiong that Mr. Yu “was that special helpful man,” while also stating, “To tell you the truth, he did help us a lot.” *Id.* at No. 85; *see also id.* at No. 71 (Mr. Yu provided “a lot of data”); Tr. (Xiong) at 73:13–17 (“Mr. Xie told me that Mr. Yu did ask him to develop the machines, you know, this product line, and I’m aware that, okay, Mr. Yu does disclose a lot of confidential agreement, confidential information to Green Giant and I was very concerned about that.”).

In addition, the evidence demonstrates that, after Vego Garden’s trade secret information allowed Green Giant to enter the market quickly, and without incurring the expenses Vego Garden expended in developing its products, the accused raised metal garden bed products were then priced below Vego Garden’s products. CX-0501 (Li Dep.) at 31:9–32:2; Tr. (Xiong) at 56:18–57:8. This caused Vego Garden to have to reduce its prices and caused it to miss out on opportunities with private equity firms. Tr. (Xiong) at 45:18–47:7. The evidence thus supports that



## PUBLIC VERSION

there is a causal nexus between Respondents' unfair act of trade secret misappropriation and the substantial injury to Vego Garden's domestic industry.

### **b) There Is a Causal Nexus Between Utopban's False Advertising and Vego Garden's Injury**

To demonstrate a violation under section 337(a)(1)(A), a complainant must demonstrate a causal nexus between respondent's unfair acts and its injury. *Rubber Resins*, Inv. No. 337-TA-848, Comm'n Op. at 61. Similarly, "to succeed on a false advertising claim under the Lanham Act, a plaintiff must show, besides the other elements, that it has been or is likely to be injured as a result of a false or misleading statement of fact." *Food Processing Equipment*, Inv. No. 337-TA-1161, Initial Determination at 32, *citing Verisign Inc. v. XYZ.com LLC*, 848 F.3d 292, 298–99 (4th Cir. 2017). Vego Garden thus must show that Utopban's false advertising caused it substantial injury.

The evidence here demonstrates that Utopban's use of Vego Garden's photographs in its advertising on its website and on its Instagram account caused customers to believe they were purchasing Vego Garden products when they were not. The evidence also shows that Utopban's use of Vego Garden's photographs influenced customers' purchasing decisions and that customers purchased Utopban's raised garden beds because of its use of Vego Garden's photographs.

This was shown in communications to Vego Garden. During the period between at least February 2022 through August 2022, when Utopban was admittedly using Vego Garden photographs in its advertising on its website and on its Instagram, customers indicated in communications to Vego Garden that they had or intended to purchase Utopban raised garden beds because of Utopban's use of Vego Garden photographs. CX-0001 (Feb. 2022, Vego Garden responding to customer requesting order confirmation after placing an order through Utopban's

## PUBLIC VERSION

website (www.vegega.com): “We looked into Vegega and it looks like they are using most of our pictures from our site” and advising consumer to cancel their order with Vegega); CX-0002 (Apr. 2022, customer communicating with Vego Garden that “I ordered through vegega.com. Looks identical to your product” and “There [sic, their] pics of products are almost identical to yours. I hope its [sic] not a bait and switch situation”); CX-0003 (May 2022, from customer to Vego Garden: “After ordering I realized they were not from your company but from Vegega, a Chinese company. They seem to be the very same beds though” and noting the lower price of Utopban raised metal garden bed products).

In addition, Mr. Li, the general manager of Utopban, testified that he was aware of instances in which customers were confused between Vego Garden products and products marketed by Utopban/Vegega. Tr. (Li) at 325:3–20. Mr. Li testified that users of Utopban’s Instagram account asked Utopban, “why are we using someone else’s photo to illustrate our own product?” Tr. (Li) at 312:23–313:7. An internal Utopban document confirms confusion between Vego Garden and Utopban. CX-0080C; CX-0501 (Li Dep.) at 45:17–46:2 (confirming that CX-0080C shows that customer was confused between Vego Garden’s and Utopban’s raised metal garden bed products).

Circumstantial evidence also supports injury to Vego Garden because of Utopban’s use of Vego Garden’s photographs. The evidence shows that Utopban used Vego Garden’s photographs from at least February through August 2022, a period of five months when Utopban and Green Giant were attempting to establish a foothold in the U.S. market. *See* Tr. (Li) at 317:20–23. Mr. Li testified that, immediately upon learning of Utopban’s use of Vego Garden’s photographs, he instructed his employees to take down the Vego Garden photographs. *Id.* at 312:23–313:7 (“once this was reported to me by our employees, I immediately instructed them to take down those photos

## PUBLIC VERSION

within two hours of that alert from the customer or the IG, Instagram user, and it was on the same day, August 3rd”). The immediacy with which Utopban contends it stopped using the Vego Garden photographs upon being told what it must have known when it selected and continued to use those photographs, that consumers would believe Utopban’s products were Vego Garden products, supports an inference that Utopban actually knew its use of such photographs injured Vego Garden. Further, the evidence supports that Utopban’s use of Vego Garden’s photographs to advertise its products caused Vego Garden to lose revenue and profits, caused damage to Vego Garden’s reputation, and caused Vego Garden to lose credibility and opportunities with private equity companies. Tr. (Xiong) at 44:12–47:7.

Utopban contends, multiple times, that its use of Vego Garden’s photographs was “accidental.” Respondents *Abitron* Br. at 3 (EDIS Doc. ID 802113). The evidence does not support this assertion. At the evidentiary hearing, Mr. Li testified that when its raised garden bed business first started, Utopban “didn’t have any good looking photos” but “wanted to show the scenarios where these garden beds can be used at or in.” CX-0501 (Li Dep.) at 50:21–24. To accomplish this, a Utopban employee found the Vego Garden photographs and used them to “illustrate the [Utopban] products’ use case, our products’ use case.” Tr. (Li) at 312:11–22. The evidence also shows that multiple Utopban customers communicated confusion to Utopban because of its use of Vego Garden photographs. *Id.* at 325:12–13. In addition, Utopban used Vego Garden’s photographs for several months at an important time, when it was just entering the market. The evidence does not support that Utopban’s use of Vego Garden’s photographs to advertise its own products was anything other than a calculated and ultimately successful effort to lead consumers to believe they were purchasing Vego Garden’s products when Utopban was launching itself into the market.

## PUBLIC VERSION

As explained in section IX.A.1.b, Vego Garden has demonstrated that it has a domestic industry with respect to its research and development and testing in the United States of its raised metal garden bed products. Utopban's selection and continued use of photographs of Vego Garden's products – the same products that are the subject of Vego Garden's research and development and testing – when it entered the raised metal garden bed market, which caused both Vego Garden and Utopban customers to believe that Vego Garden's products were Utopban's products, demonstrates that there is a causal nexus between Utopban's false advertising and the substantial injury to Vego Garden's domestic industry.

### X. CONCLUSIONS OF LAW

1. The Commission has statutory jurisdiction with respect to Vego Garden's allegations of trade secret misappropriation.
2. The Commission has statutory jurisdiction with respect to Vego Garden's allegations of false advertising.
3. The Commission has personal jurisdiction over the parties.
4. The Commission has *in rem* jurisdiction over the accused products.
5. The importation requirement of section 337 is satisfied with respect to both Green Giant and Utopban.
6. Green Giant has misappropriated certain of Vego Garden's trade secrets.
7. Utopban has engaged in false advertising under 15 U.S.C. § 1125(a)(1).
8. Vego Garden has demonstrated that it has a domestic industry with respect to its raised metal garden bed products.
9. Vego Garden has demonstrated substantial injury to its domestic industry.

## PUBLIC VERSION

10. A violation of 19 U.S.C. § 1337 has been shown by the importation and sale of raised metal garden beds and components thereof.

### **XI. RECOMMENDED DETERMINATION ON REMEDY AND BOND**

The Commission has broad discretion in selecting the form, scope, and extent of any remedy. *Viscofan, S.A. v. Int'l Trade Comm'n*, 787 F.2d 544, 548 (Fed. Cir. 1986); *see also Hyundai Electronics Industries Co. Ltd. v. Int'l Trade Comm'n*, 899 F.2d 1204, 1209 (Fed. Cir. 1990). By Commission rule, the administrative law judge must issue a recommended determination on the appropriate remedy if the Commission finds a violation of section 337 and on the amount of bond to be posted by respondents during Presidential review of any Commission remedy. *See* 19 C.F.R. § 210.42(a)(1)(ii). I address these issues below.

#### **A. Limited Exclusion Orders**

Section 337(d)(1) provides that “[i]f the Commission determines, as a result of an investigation under this section, that there is a violation of this section, it shall direct that the articles concerned, imported by any person violating the provision of this section, be excluded from entry into the United States, unless, after considering the [public interest], it finds that such articles should not be excluded from entry.” 19 U.S.C. § 1337(d)(1). The Commission is required to issue an exclusion order upon the finding of a Section 337 violation absent a finding that the effects of one of the statutorily-enumerated public interest factors counsel otherwise.<sup>48</sup> *Spansion v. Int'l Trade Comm'n*, 629 F.3d 1331, 1358 (Fed. Cir. 2010).

---

<sup>48</sup> The issue of public interest was not delegated by the Commission in the Notice of Investigation. *See* 87 Fed. Reg. 63527. Nonetheless, Vego Garden addressed the public interest in its briefing. Complainant Pre-Hearing Br. at 34–36 and Complainant Post-Hearing Br. at 49–51. So did Respondents. Respondents Post-Hearing Resp. Br. at 49–50. Oddly, in addition to addressing public interest on the merits, Respondents contend that “the Commission should not simply

## PUBLIC VERSION

I separately address my recommendations with respect to trade secret misappropriation and false advertising below.

### 1. Limited Exclusion Order Addressing Trade Secret Misappropriation

As an initial matter, Vego Garden asserted in its pre-hearing brief that “a limited exclusion order of no less than 12 months and no more than 18 months is appropriate.” Complainant Pre-Hearing Br. at 32. In its post-hearing brief, Vego Garden contends that “a limited exclusion order of no less than 12 months and no more than 36 months is appropriate.” Complainant Post-Hearing Br. at 47. In response to the Staff’s argument that it waived the right to argue for an exclusion order beyond 18 months, Staff Post Hearing Br. at 63, n.32, Vego Garden does not dispute what it argued in its pre-hearing brief but contends that the “parties now have the benefit of an evidentiary record developed during the hearing.” Complainant Post-Hearing Resp. Br. at 24, n.5. The record developed at the evidentiary hearing on this point, however, is testimony from Vego Garden’s CEO, which was uniquely within the control of Vego Garden. I agree with the Staff that Vego Garden has waived any contention that a limited exclusion order of greater than 18 months is appropriate. *See* Order No. 14 at Ground Rule 11.2.

On the merits, the duration of a limited exclusion order in an investigation involving trade secret misappropriation is set as the time it would have taken to independently develop the trade secrets. *Rubber Resins*, Inv. No. 337-TA-849, Comm’n Op. at 82. Respondents contend that Vego

---

delegate the public interest determination to the Administrative Law Judge without proper consideration.” *Id.* at 49. The Commission has made clear that when public interest is not delegated “the ALJ [i]s not authorized to make findings or recommendations relating to public interest.” *Certain Automated Put Walls and Automated Storage and Retrieval Systems, Associated Control Software, and Component Parts Thereof*, Inv. No. 337-TA-1293, Comm’n Op. at 29, n.25 (Jul. 31, 2023) (EDIS Doc. ID 802614) (*Automated Put Walls*). Because public interest was not delegated, I do not address the private parties’ public interest arguments.

## PUBLIC VERSION

Garden did not provide evidence regarding how long it would have taken a company in their position to have independently developed Vego Garden's trade secrets and only provided evidence of how long it took Vego Garden to develop its trade secrets. Respondents Post-Hearing Resp. Br. at 48. In determining how long it would have taken a respondent to develop the misappropriated trade secrets, however, the Commission may consider the length of time it took the complainant to develop the secrets and the resources of a respondent. *Sausage Casings*, Inv. Nos. 337-TA-148/169, Comm'n Op. at 19–20. Those two issues are addressed below.

Mr. Xiong testified each of the asserted trade secrets was the result of around 1 year of research and development efforts. Tr. (Xiong) at 57:24–59:1 (research and development to bring an 8-inch product line to market took 12 months), 61:6–62:1 (selection of protective film took a year), and 66:14–67:6 (machine design improvements took a year to research and develop). Respondents contend that any limited exclusion order should be limited in time, but do not provide evidence or argument regarding the amount of time it would have taken them to independently develop the asserted trade secrets. Respondents Post-Hearing Br. at 37–38 and Respondents Post-Hearing Resp. Br. at 48.

As for the resources of Green Giant, the evidence demonstrates that Green Giant was not in a position to independently develop the asserted trade secrets any more quickly than Vego Garden. Instead, the evidence shows that Green Giant was only recently formed and appears to be a small company. In addition, because Green Giant apparently did not have sufficient internal resources, it was having difficulty developing and manufacturing its own raised metal garden products. As a result, Green Giant secured the assistance of Mr. Yu and was only then able to quickly get to market using Vego Garden's trade secret information. *See* CX-0037 at No. 141 (Mr. Yu was introduced to Green Giant because Green Giant “ha[s] some technical difficulties that we

## PUBLIC VERSION

cannot overcome”), at No. 85 (Mr. Xie of Green Giant stating that “three months are not enough, not enough at all ... To us Yu Xiong was that special helpful man. To tell you the truth, he did help us a lot, right”), and at No. 81 (“Yu Xiong did give us some constructive suggestions . . . In fact, we just entered this industry, up until now a lot of stuff are done in reference to his standards”).

While Respondents contend that a limited exclusion order should not issue, they do not address or provide evidence regarding a specific time period of an exclusion order with respect to any individual trade secret or the trade secrets globally. Respondents Post-Hearing Br. at 37–38; and Respondents Post-Hearing Resp. Br. at 48. The Staff contends that a limited exclusion order of no more than 12 months is appropriate, based on the development time of the asserted trade secrets. Staff Post-Hearing Br. at 64.

With that backdrop, each of the asserted trade secrets is addressed separately.

### **a) The 8-Inch Product Development Trade Secret**

As to the 8-inch product development trade secret, in view of the evidence, including the length of time for development by Vego Garden (12 months) and the resources of Green Giant (not greater than Vego Garden), I recommend a limited exclusion order of 12 months. In addition, the evidence supports that only Green Giant’s 8-inch raised metal garden bed products are made using the misappropriated 8-inch product development trade secret.

Accordingly, to the extent the Commission finds a violation with respect to the 8-inch product development trade secret, I recommend a limited exclusion order directed to those entities involved in the sale for importation, importation, and sale after importation of Green Giant’s 8-inch raised metal garden bed products and components thereof for a duration of 12 months.

In addition, because there is no evidence that the asserted trade secrets could not have been developed simultaneously, I recommend that, to the extent the Commission finds a violation with



## PUBLIC VERSION

respect to either of the other asserted trade secrets, and those trade secrets are incorporated in Green Giant's 8-inch products, the time periods of such exclusion orders run concurrently.

### **b) The Protective Film Trade Secret**

As to the protective film trade secret, in view of the evidence, including the length of time for development by Vego Garden (12 months) and the resources of Green Giant (not greater than Vego Garden), if the Commission concludes there is a violation with respect to Vego Garden's protective film trade secret, I recommend a limited exclusion order of 12 months. In addition, the evidence supports that all of Green Giant's raised metal garden bed products are made using the protective film trade secret. Tr. (Lu) at 366:1–8 (Green Giant uses the same supplier for all of its protective films); *id.* at 367:13–25 (“I went with the glueless option, which makes it easy to remove”). Accordingly, to the extent the Commission finds a violation with respect to the protective film trade secret, I recommend a limited exclusion order directed to those entities involved in the sale for importation, importation, and sale after importation of all of Green Giant's raised metal garden bed products and components thereof for a duration of 12 months.

In addition, because there is no evidence that the asserted trade secrets could not have been developed simultaneously, I recommend that, to the extent the Commission finds a violation with respect to either of the other asserted trade secrets, and those trade secrets are incorporated in Green Giant's products, the time periods of such exclusion orders run concurrently.

### **c) The Bending Machine Trade Secret**

Mr. Xiong testified that he started working on raised metal garden bed products around the beginning of 2020, sold his first product in July 2020, and formally founded Vego Garden at the end of 2020. Tr. (Xiong) at 25:8–22. The subject matter of Vego Garden's bending machine trade secret became public with the publication of Chinese Patent Application CN 214719610U on

## PUBLIC VERSION

November 16, 2021. Complainant Post-Hearing Br. at 14; and JX-0021. The evidence thus supports that the time between when the earliest Vego Garden raised metal garden bed was made using the bending machine trade secret to the publication of that trade secret was at most around 16 months.

In view of the evidence, including the length of time for development by Vego Garden (12 months), the resources of Green Giant (not greater than Vego Garden), and the time period of secrecy (no more than 16 months), if the Commission concludes there is a violation with respect to Vego Garden's bending machine trade secret, I recommend a limited exclusion order of 12 months. In addition, the evidence supports that all of Green Giant's raised metal garden bed products are made using the bending machine trade secret. *See* JX-0001. As a result, to the extent the Commission finds a violation with respect to the bending machine trade secret, I recommend issuance of a limited exclusion order directed to those entities involved in the sale for importation, importation, and sale after importation of all of Green Giant's raised metal garden bed products and components thereof for a duration of 12 months. In addition, because there is no evidence that the asserted trade secrets could not have been developed simultaneously, I recommend that, to the extent the Commission finds a violation with respect to either of the other asserted trade secrets, and those trade secrets are incorporated in Green Giant's products, the time periods of such exclusion orders run concurrently.

### **2. Limited Exclusion Order Addressing False Advertising**

As noted by the Staff, having determined that there was a violation of section 337 based on false advertising, the Commission has issued remedial orders that were not time-limited, instead prohibiting the respondent from importing falsely-advertised products. Staff Post-Hearing Br. at 64, *citing Woven Textile Fabrics*, Inv. No. 337-TA-976, General Exclusion Order at 1 ("the

## PUBLIC VERSION

Commission has determined to issue a general exclusion order prohibiting the importation of woven textile fabrics and products containing same that are falsely advertised through the misrepresentation of thread counts”) (EDIS Doc. ID 605891). As addressed above, the Supreme Court recently clarified that 15 U.S.C. § 1125(a)(1) is directed to unauthorized use in domestic commerce of a protected trademark when, among other things, that use is likely to cause confusion. *Abitron*, Slip Op. at 14–15. Considering that guidance, I recommend that if the Commission determines that there is a violation of section 337 with respect to false advertising, any limited exclusion order prohibit the importation by Utopban of raised garden beds and components thereof falsely-advertised in the United States by use of any Vego Garden photograph.

Vego Garden and the Staff both recognize that a certification provision “may be appropriate to minimize the possibility that any non-covered products will be excluded from entry.” Complainant Post-Hearing Br. at 46; and Staff Post-Hearing Br. at 62. Utopban contends that it has stopped using Vego Garden’s photographs to advertise its products, Respondents Post-Hearing Br. at 27, 37, and there is no record evidence suggesting that is not the case. To minimize the possibility that non-covered products will be excluded from entry, and in view of the clarification of 15 U.S.C. § 1125(a)(1) provided by the Supreme Court in *Abitron*, requiring use of a false advertisement in domestic commerce for a § 1125(a)(1) claim, I recommend that any limited exclusion order include a provision allowing Utopban to certify that the imported raised metal garden beds and components thereof were not falsely advertised in the United States by use of any Vego Garden photograph.

### **B. Cease and Desist Orders**

Section 337(f)(1) provides that in addition to, or in lieu of, the issuance of an exclusion order, the Commission may issue a cease and desist order as a remedy for violation of section 337.

## PUBLIC VERSION

19 U.S.C. § 1337(f)(1). A cease and desist order is generally issued when a respondent maintains commercially significant inventories in the United States or has significant domestic operations that could undercut the remedy provided by an exclusion order. *Certain Table Saws Incorporating Active Injury Mitigation Technology & Components Thereof*, Inv. No. 337-TA-965, Comm’n Op. at 4–6 (Feb. 1, 2017) (EDIS Doc. ID 602496). “A complainant seeking a cease and desist order must demonstrate, based on the record, that this remedy is necessary to address the violation found in the investigation so as to not undercut the relief provided by the exclusion order.” *Id.* at 5.

Vego Garden appears to seek a cease and desist order only as to Utopban, which it contends maintains inventory of raised garden bed products in third-party warehouses in Los Angeles and New Jersey. Complainant Post-Hearing Br. at 47–48. The Staff agrees that a cease and desist order is warranted as to Utopban. Staff Post-Hearing Br. at 64–65.

Under the name Vegega, Utopban has at least one facility in the United States. Amended Complaint, ¶ 3.2 (identifying Vegega as having a location at 2646 River Ave., Suite #A, Rosemead, CA 91770). As to whether Utopban maintains significant inventory in the United States, Mr. Li testified that Utopban keeps several hundred units of raised garden bed products in inventory in each of two third-party warehouses in Los Angeles and New Jersey. Tr. (Li) at 326:19–327:24; *see also* CX-0501 (Li Dep.) at 24:4–26:5 (addressing inventory maintained in Los Angeles and New Jersey, with a larger volume of inventory in Los Angeles and stating that Utopban has moved to a model “where we order things ahead of time and keep them in stock, and then [] have the inventory shipped out from the warehouse as the orders come in”). In addition, in Exhibit A to its response to the amended complaint, Utopban represented that “[t]he quantity of Utopban Limited’s accused products imported into the US in the year prior to filing this response on December 5, 2022, is 5350.” Exhibit A to Utopban Response to Complaint, ¶ a. Given the

## PUBLIC VERSION

volume of raised garden beds that Utopban has imported, I find that an inventory of several hundred products in each of Utopban's Los Angeles and New Jersey warehouses is significant.

Respondents contend that Utopban “only imports limited inventory of goods into the United States” and is “not engaged in significant business activities in the United States since there are much more competitors in the market that directly compete with Complainants.” Respondents Post-Hearing Br. at 38. Respondents do not address that Utopban has at least one facility in the United States. Respondents also do not address the testimony of Mr. Li that Utopban maintains several hundred of Green Giant's raised garden bed products in each of two warehouses in the United States. Nor do Respondents dispute that Utopban's inventory in the United States has increased over time. *See* Respondents Post-Hearing Br. at 38–39; and Respondents Post-Hearing Resp. Br. at 48.

The evidence demonstrates that Utopban maintains a significant inventory of raised garden bed products at warehouses in Los Angeles and New Jersey and that it has increased or plans to increase the use of U.S. inventory for storage of its products. As a result, if the Commission finds a violation as to Utopban, I recommend issuance of a cease and desist order.

### **C. Bond During Presidential Review**

When the Commission enters an exclusion order or a cease and desist order, a respondent may continue to import and sell its products during the 60-day Presidential review period under an amount determined by the Commission to be “sufficient to protect the complainant from any injury.” 19 U.S.C. § 1337(j)(3); *see also* 19 C.F.R. § 210.50(a)(3); and *Automated Put Walls, Inv. No. 337-TA-1293, Comm'n Op. at 46*. Vego Garden bears the burden of establishing the need for a bond. *Automated Put Walls, Inv. No. 337-TA-1293, Comm'n Op. at 47*.

## PUBLIC VERSION

Respondents did not substantively address the appropriate bond in their pre-hearing brief. Respondents do not argue that they were not aware of the issue, nor could they. Respondents' pre-hearing brief contains a section titled "Remedy and Bond," but neither that section nor any other section of their brief substantively addresses the issue. Respondents Pre-Hearing Br. at iii and 34–36. Respondents have, therefore, waived this issue. *See* Order No. 14 (Ground Rules) at Ground Rule 11.2; *see also* Staff Post-Hearing Br. at 66–67, n.34. Nevertheless, Respondents contend in their post-hearing brief that Vego Garden "has not established that it will be harmed as a result of any products imported during the Presidential review period." Respondents Post-Hearing Br. at 39.

The evidence demonstrates that Respondents directly compete with and target and sell to the same customers as Vego Garden. Tr. (Xiong) at 42:10–14 (identifying Vegega as a competitor to Vego Garden); Tr. (Xiong) at 43:6–14 (identifying Green Giant customers as competitors in the United States); CX-0501 (Li Dep.) at 35:22–25 (identifying Vego Gardens as selling the same products as Utopban). The evidence also demonstrates that Vego Garden has experienced substantial injury to its domestic industry. *See* section IX.B. I therefore conclude that a bond is necessary to prevent injury to Vego Garden during the Presidential review period.

When reliable price information is in the record, the Commission often sets the bond by eliminating the differential between the domestic product and the imported product. *Automated Put Walls*, Inv. No. 337-TA-1293, Comm'n Op. at 46. The Commission may also use a reasonable royalty rate to set the bond amount where one can be determined from the record. *Id.* Where the record establishes that the calculation of a price differential is impractical or there is insufficient evidence in the record to determine a reasonable royalty, the Commission has imposed a 100 percent bond. *Id.*

## PUBLIC VERSION

Vego Garden asserts that a 100% bond is appropriate because a price differential comparison is not possible and there is no reasonable royalty rate. Complainant Pre-Hearing Br. at 33–34; Complainant Post-Hearing Br. at 48–49. The Staff agrees. Staff Post-Hearing Br. at 66.

Mr. Xiong, the founder of Vego Garden, testified that Vego Garden was forced to reduce the prices of its raised metal garden bed products because of Respondents' entry into the market but that those price reductions were not uniform because Respondents sold into various channels, including Amazon and a proprietary website. Tr. (Xiong) at 45:18–46:5. Mr. Xiong also testified that Vego Garden sells raised metal garden bed products in three different heights, and in each of those heights has five different configurations, with different prices. *Id.* at 198:6–199:11. Mr. Li of Utopban testified that he did not intend to price the Respondents' products higher than those of Vego Garden but did not provide any testimony or other evidence of any specific price differentials between Respondents' products and those of Vego Garden. CX-0501 (Li Dep.) at 31:9–32:2.

Respondents contend that Vego Garden “has not established any reliable basis for a bond rate of [sic], for it has presented no quantitative analysis of any price difference between the domestic industry products and the accused products, or a reasonable royalty rate.” Respondents Post-Hearing Br. at 39. When that is the case, however, a bond of 100% is appropriate.

The evidence demonstrates that calculation of a price differential is not feasible. The evidence also does not demonstrate that there is any set royalty rate. *See* Staff Post-Hearing Br. at 66, n.33. In view of the record evidence, I recommend that the Commission set a 100% bond for any importation of Respondents' raised metal garden bed products and components thereof during the Presidential review period.

## **PUBLIC VERSION**

### **XII. INITIAL DETERMINATION ON VIOLATION**

It is my initial determination that a violation of section 337 of the Tariff Act, as amended, has occurred by the importation into the United States, the sale for importation, or the sale within the United States after importation of raised metal garden beds and components thereof by Respondents Green Giant and Utopban. I hereby certify this Initial Determination and Recommended Determination to the Commission.

The Secretary shall serve the confidential version of this Initial Determination and Recommended Determination upon counsel who are signatories to the Protective Order (Order No. 1) issued in this investigation. A public version will be served on all parties of record later.

Pursuant to 19 C.F.R. § 210.42(h), this Initial Determination shall become the determination of the Commission unless a party files a petition for review under 19 C.F.R. § 210.43(a) or the Commission orders on its own motion a review of the Initial Determination or certain issues therein under 19 C.F.R. § 210.44.

### **XIII. ORDER**

Within seven days of the date of this document, the parties shall jointly submit a single proposed public version with any proposed redactions indicated in red. If the parties submit excessive redactions, they may be required to provide declarations from individuals with personal knowledge, justifying each proposed redaction and specifically explaining why the information sought to be redacted meets the definition for confidential business information set forth in 19 C.F.R. § 201.6(a). The proposed redactions should be made electronically, in a single PDF file using the “Redact Tool” within Adobe Acrobat. The proposed redactions should be submitted as “marked” but not yet “applied.” The proposed redactions should be submitted via email to JohnsonHines1334@usitc.gov and not filed on EDIS.



SO ORDERED.



Doris Johnson Hines  
Administrative Law Judge